

# ACCESSORY FITMENT INSTRUCTION

**Product**

Isuzu Dmax Double cab side steps

**Part no.**

160030T & BS-160031, 160031T , BS-160031



60  
Minutes

Models : Double Cab & EC

Page 1 of 5

Date : 15-Oct-2019

DIAGRAM



Kit content:

	Qty	Description		Qty	Description
A	6	M8x25 Sets	H	12	M8 Spring washersc (Black)
B	6	M8 hex nuts	I	4	Front and middle bracket(PS+DS)
C	12	M8x20x1.6 Flat washers	j	2	Rear bracket(PS+DS)
D	12	M8 Spring washers			
E	12	M8x25 Sets (Black)			
F	12	M8 hex nuts (Black)			
G	24	M8x20x1.6 Flat washers (Black)			

Additional equipment/Material needed for fitment :

Qty	1	Socket Set	Qty	
	1	Spanner Set		
	1	Torque wrench		
		Settings : M8 = 22Nm		

Precautions during fitment:

1. Remove standard running board if present before beginning the fitment.
2. Avoid direct contact with sharp objects when removing the packaging.

Directions for use:

1. Have the side steps placed on a rubber mat to avoid any damage during fitment
2. Ensure steps are secure and not hindering the body of the vehicle before signing of the fitment.

## Fitment Instruction: Dolsuzu Dmax Double cab side steps

Visual / Graphic Illustration

Step #

Description/Method

Fig 1

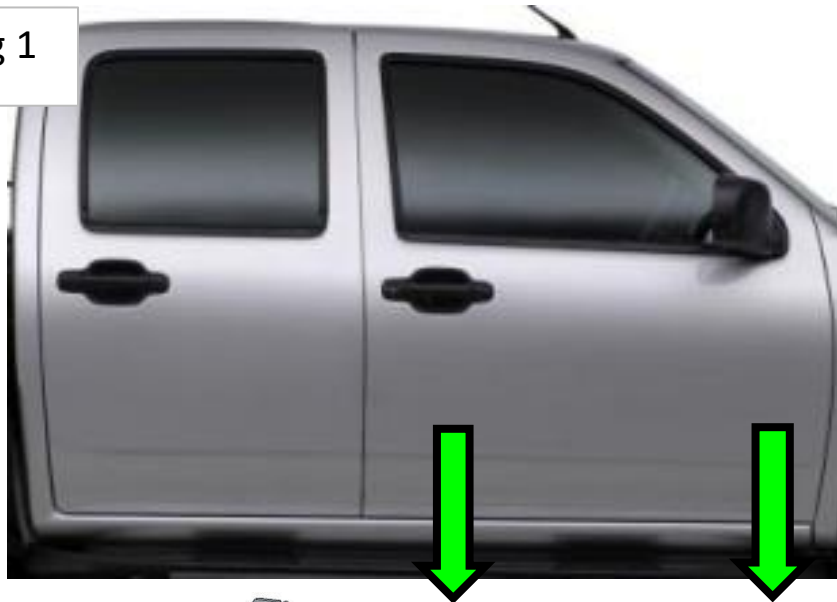

Step 1

Using the brackets from the kit marked DF and DM, attach it to the body on the points provided and tighten to the specified torque (M8 = 22 Nm).

Refer to Fig 1,2 and 3.

Fitment of brackets on both sides is the same.

Fig 2

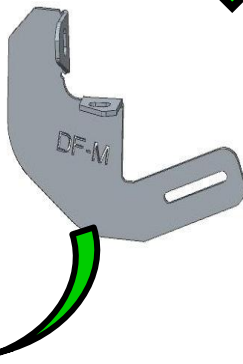
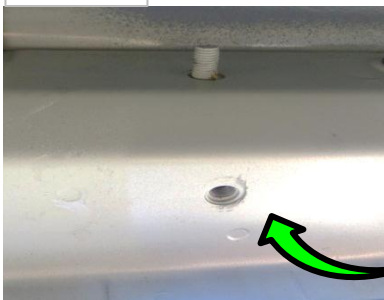

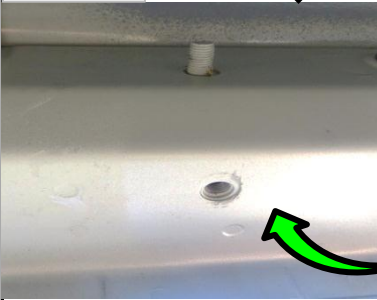
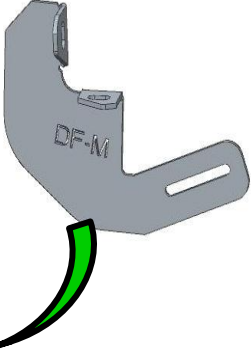

Fig 3



## Fitment Instruction: Isuzu Dmax Double cab side steps

Visual / Graphic Illustration	Step #	Description/Method
	<p><b>Step 2</b></p>	<p>Using the bracket from the kit marked DB, attach it to the body on the points provided and tighten to the specified torque (M8 = 22 Nm).</p> <p style="text-align: center;">Refer to Fig 4, 5 and 6.</p>
		<p>Fitment of brackets on both sides is the same.</p>
		

**Fitment Instruction:**  
Isuzu Dmax Double cab side steps

Visual / Graphic Illustration

Step #

Description/Method

FIG 7

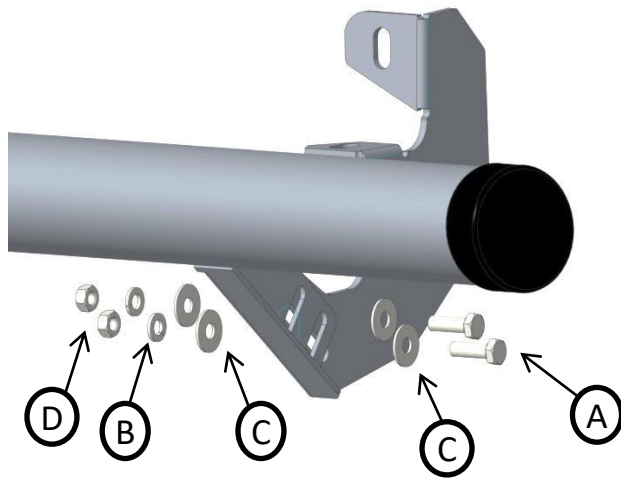

Step 3

Attach the oval side step to the brackets mounted to the vehicle using the kit (FIG 7).

Step 4

Tighten all bolts and nuts.

Complete

## Final step

Page 5 of 5

Make sure bar is centralised and tighten all fasteners to specified torque. M8= 22Nm , M10= 42Nm , M6= 9Nm.

