

# ACCESSORY FITMENT

**Product**

VW Crafter 2018 Side Step Stainless LWB\_BOM

**Part no.**

Part No. 250048T (Tracking No. 161)



45  
Minutes

Models : VW Crafter 2018 LWB

Page 1 of 7

Date : 23-Aug-2018

## DIAGRAM

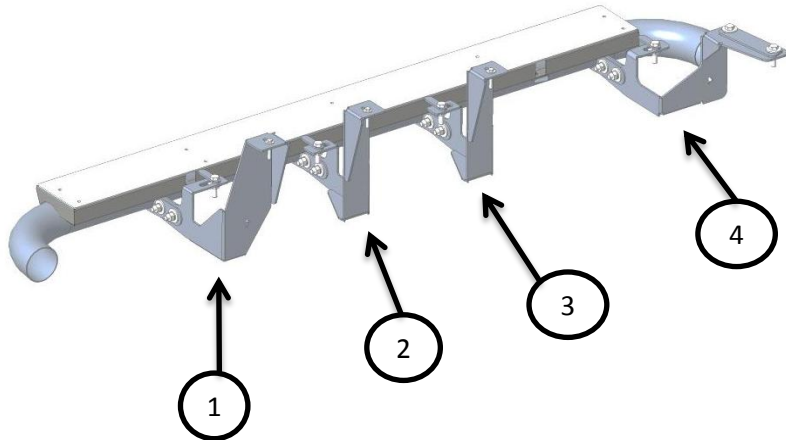

Velamoid

## Kit content:

	Qty	Description		Qty	Description
A	1	Side Step	J	6	M6 Flat Washer x $\phi$ 20 x 2mm THK
B	1	Bracket No. 1	K	3	M6 Nyloc Nut
C	1	Bracket No. 2	L	2	M10 Set Screws x 40mm Long
D	1	Bracket No. 3	M	8	M10 Set Screws x 30mm Long
E	1	Bracket No. 4	N	24	M10 Flat Washer x $\phi$ 30 x 2.5mm THK
F	1	Support Plate	O	14	M10 Nyloc Nuts
G	6	Velamoid			
H	4	T-Bolt, M10 x 40			
I	3	M6 Set Screw x 40mm Long			

## Additional equipment/Material needed for fitment :

Qty		Qty	
	Socket & Ratchet Set		Spline Key Set
	Spanner Set		Allen Key set
	Thin Screw Driver		

## Precautions during fitment:





Do not Cause any Damage to the Vehicle

Ensure that you are wearing the correct PPE Clothing during Installation.

## Directions for use:

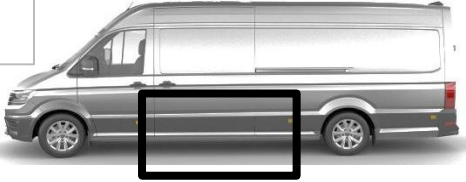
Read all Instructions Carefully Before Installation.

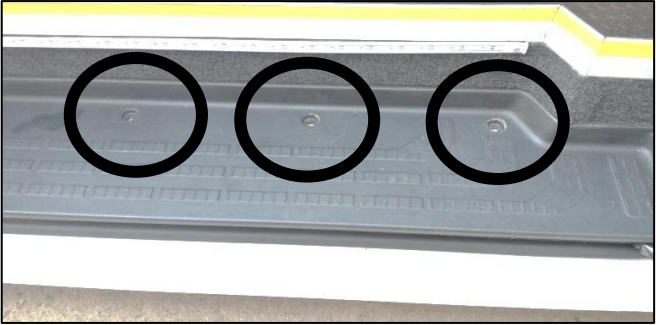
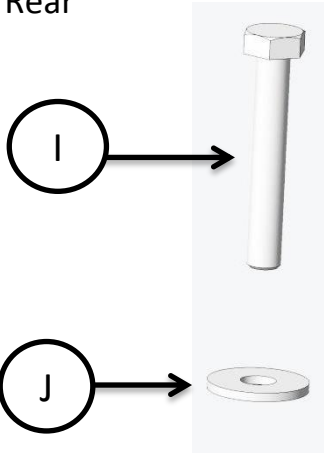
## Fitment Instruction: VW Crafter 2018 Side Step LWB

Visual / Graphic Illustration	Step #	Description/Method
<div style="display: flex; justify-content: space-around; align-items: center;"> <div style="text-align: center;"> <p>Fig. 1</p>  </div> <div style="text-align: center;"> <p>Fig. 2</p>  </div> </div>	<p>1</p>	<p>Open the Sliding Door to expose the Natural Foot Step as shown in Figure 1 &amp; Figure 2.</p>
<div style="display: flex; justify-content: space-around;"> <div style="text-align: center;"> <p>Vehicle Front</p>  </div> <div style="text-align: center;"> <p>Vehicle Rear</p>  </div> </div>	<p>2</p>	<p>Remove Grommets and M6 fasteners as shown in Figure 2.</p>
<div style="display: flex; justify-content: space-around; align-items: center;"> <div style="text-align: center;">  <p>Grommet</p> </div> <div style="text-align: center;">  <p>M6 fastener</p> </div> </div> <p style="text-align: center;">Visual / Graphic Illustration</p>	<p>3</p>	<p>Insert M6 x 40mm Set Screw and Flat washer as shown in Illustration.</p>

## Fitment Instruction: VW Crafter 2018 Side Step LWB

Visual / Graphic Illustration

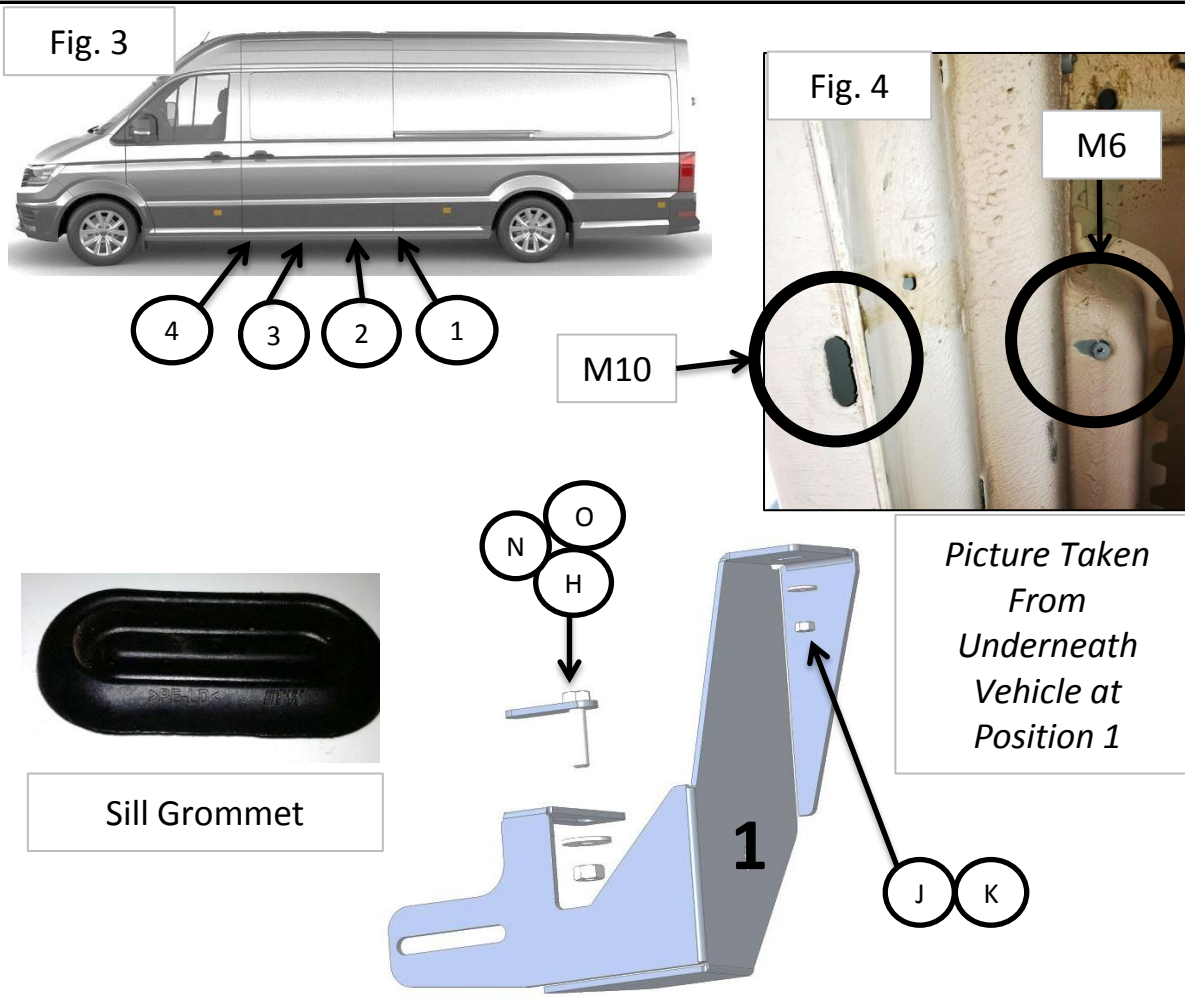

Step #

Description/Method

4

Locate the Bracket Mount Position on the Vehicle as shown in figure 3, Position 1 & Figure 4.

5

Remove the Sill Grommet and Insert T-Bolt as shown in Illustration.

6

Fit the brackets with the corresponding numbers (1 to 3) at the Positions as shown in the illustration.

7

Do not Tighten Fully

## Fitment Instruction: VW Crafter 2018 Side Step LWB

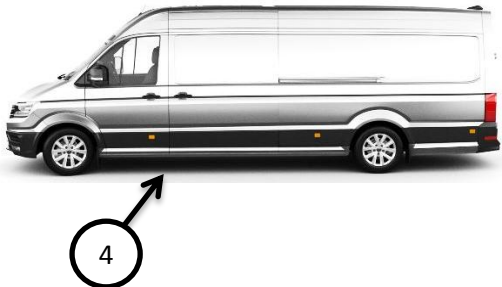
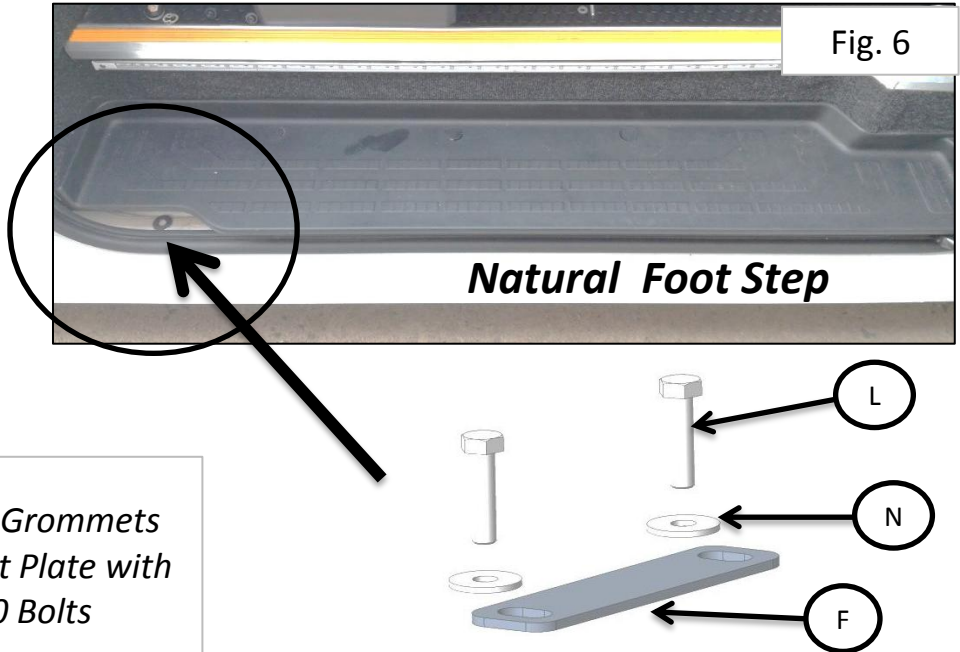
Visual / Graphic Illustration	Step #	Description/Method
 <p style="text-align: right;">Fig. 5</p>	8	Locate Bracket No. 4 Position as shown in Figure 5 & Figure 6.
 <p style="text-align: center;"><b>Natural Foot Step</b></p> <p style="text-align: right;">Fig. 6</p> <div style="border: 1px solid black; padding: 5px; width: fit-content; margin-top: 10px;"> <p><i>Remove Grommets and Insert Plate with M10 Bolts</i></p> </div>	9	Insert item Nos L, N, F as shown in figure 5 & Figure 6.

## Fitment Instruction: VW Crafter 2018 Side Step LWB

Visual / Graphic Illustration

Step #

Description/Method

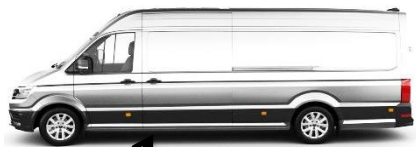

*View From Underneath Vehicle Pos. 4*



4

M10 Bolt

M10 T-Bolt

Fig. 7

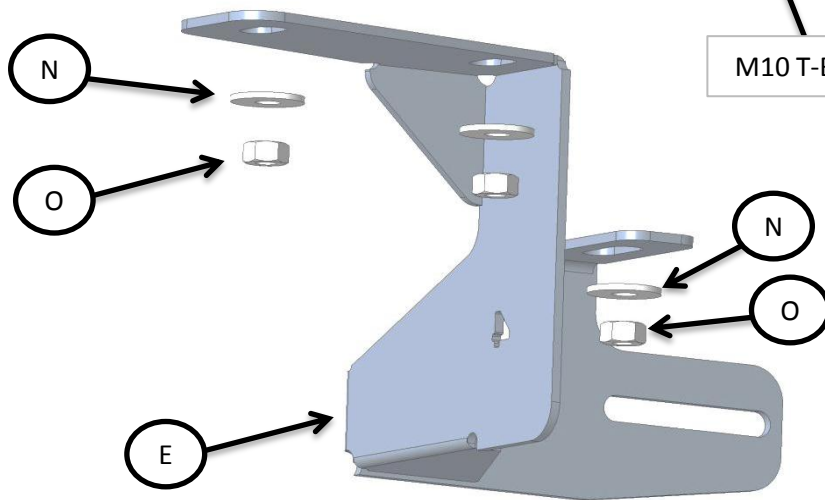

Visual / Graphic Illustration

10

Fit Bracket No. 4 as shown in Figure 7.

11

Do not tighten Fully

Make sure bar is centralised and tighten all fasteners to specified torque. M8= 22Nm , M10= 42Nm , M6= 9Nm.

