

# ACCESSORY FITMENT

**Product**

VW Amarok Front Styling Bar

**Part no.**

VW-AMAFSB-S, VW-AMAFSB-B, 250052T,  
BS-250052 TN:155



60  
Minutes

Models : ALL

Page 1 of 4

Date : 18-02-2019

DIAGRAM



Kit content:

	Qty	Description		Qty	Description
A	4	M8x30 Sets	H	2	T-bolts
B	8	M8x22x2 Flat washers	I	2	Mount plates PS and DS
C	4	M8 Spring washers	J	1	Front styling bar
D	4	M8 hex nuts	K	2	Spanner Tool
E	4	M10 spring washers	L	2	Velomoid
F	2	M10x20 Sets			
G	4	M10x22x2 Flat washer			

Additional equipment/Material needed for fitment :

Qty	Ratchet and spanner set	Qty	
	Masking tape		

Precautions during fitment:

Do not scratch the vehicle during fitment. Do not scratch the front styling bar when unpacking and during fitment.

Directions for use:

Read all instructions carefully before installation

## Fitment Instruction: Amarok Front Styling Bar

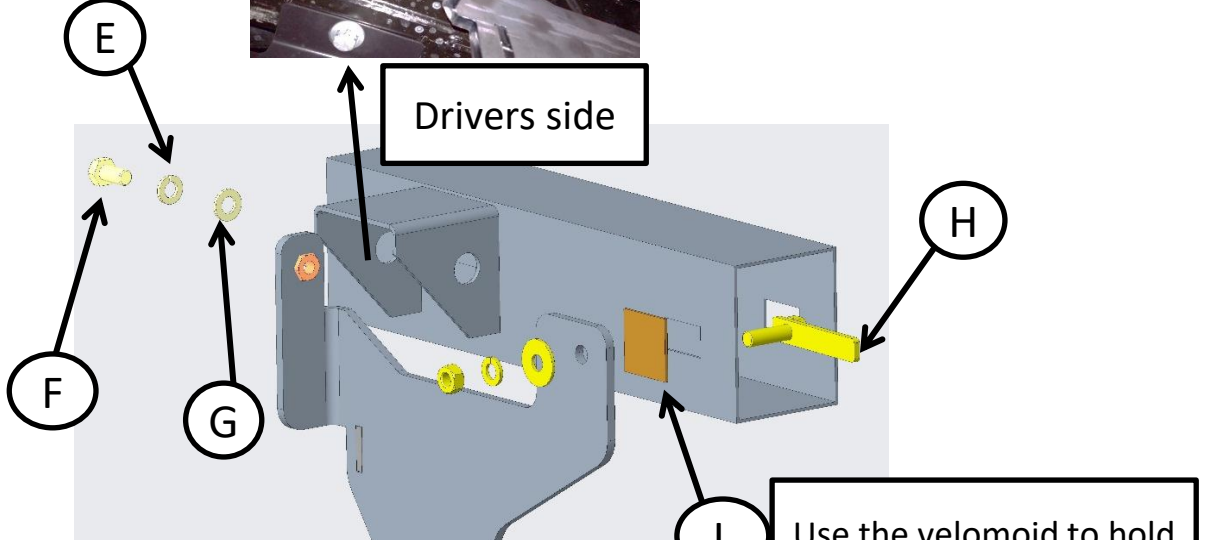
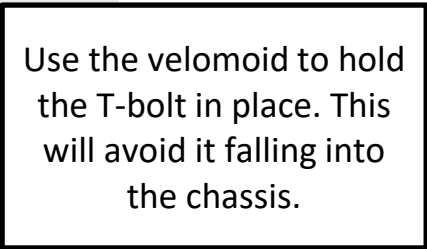
Visual / Graphic Illustration	Step #	Description/Method
 <p style="text-align: center;">FIG 1</p>	Step 1	The brackets mount to the outside of the chassis with the gusset "resting" under the chassis. Fig 1 shows how to mount the brackets.
 <p style="text-align: center;">Drivers side</p> <p style="text-align: center;">Front of vehicle</p>	Step 2	Do the same to the passengers side.
 <p style="text-align: center;">Use the velomoid to hold the T-bolt in place. This will avoid it falling into the chassis.</p>		

## Fitment Instruction: Amarok Front Styling Bar

Visual / Graphic Illustration

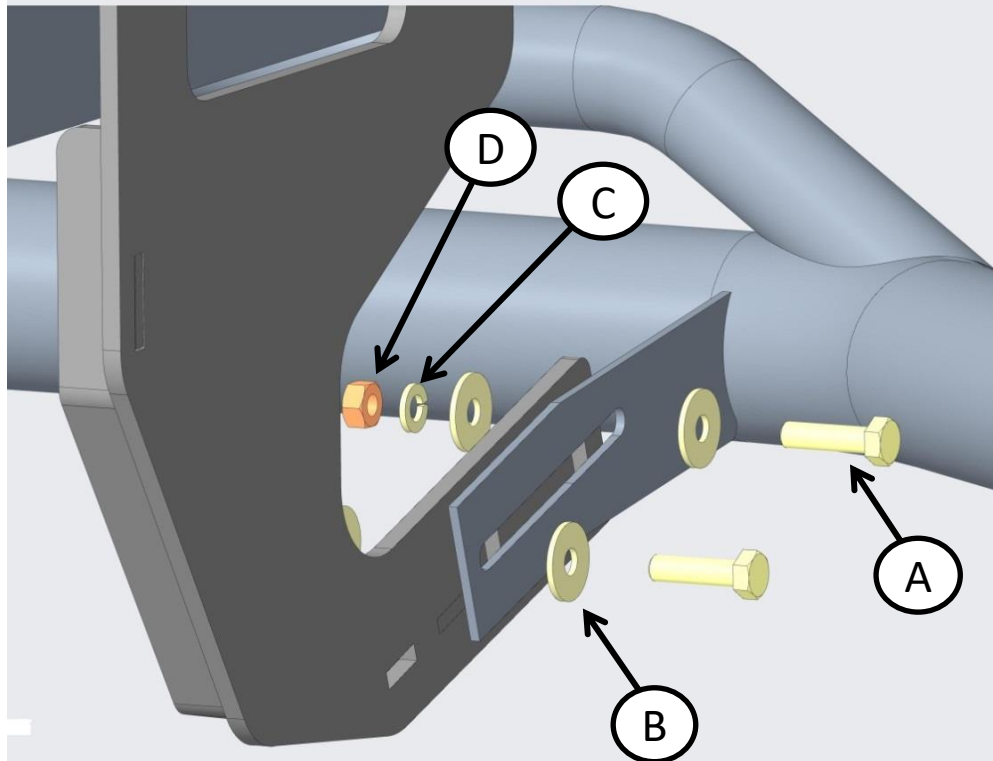

Step #

Description/Method

Step 3

Assemble the front styling bar onto the mounted brackets. Do to both sides of the vehicle.



NB : In the kit there are two spanners that look like the above image. Keep these in you vehicle. These are to remove the front styling bar if you need to gain access to the tow eye.

The mounting bracket has three slots. Use the rear two slots for vehicle models 2018 and below. Use the front two slots for models 2019 and up.

## Final step

Page 4 of 4

Make sure bar is centralised and tighten all fasteners to specified torque. M8= 22Nm , M10= 42Nm , M6= 9Nm.

