

ACCESSORY FITMENT INSTRUCTION

Product

VW Amarok Double tube side steps

Part no.

250055T, TN:363



60
Minutes

Models :DC

Page 1 of 4

Date :22/06/2020

DIAGRAM



Kit content:

	Qty	Description		Qty	Description
A	6	M10x130 Bolts	L	4	M8 x 25 x 2 flat washers
B	10	M10 Hex Nuts	M	2	Round Plates 60 Diameter
C	10	M10 Spring Washers	O	2	Rectangle Plates
D	16	M10x30x2.5 Flat Washers	P	1	Passenger Front(PF) Bracket
E	12	M8x25 Bolts	Q	1	Passenger Middle(PM) Bracket
F	14	M8 Spring Washers	R	1	Passenger Back(PB) Bracket
G	12	M8x20x1.6 Flat Washers	S	1	Drivers Front(DF) Bracket
H	2	M8 Nuts	T	1	Drivers Middle(DM) Bracket
I		Velamoid	U	1	Drivers Back(DB) Bracket
J	4	T-Bolts 20x110x10mm			
K	2	M8 X 30 Bolts			

Additional equipment/Material needed for fitment :

Qty	Description		
1	13 Spanner	1	15 Spanner
1	3/8 Drive Set		

Precautions during fitment:

Ensure that your workmanship is of the highest professional standard and that you do not scratch or damage the vehicle or accessory to be fitted. Take care not to scratch the parts when removing from the packaging

Directions for use:

Follow the fitting instruction carefully

Fitment Instruction: VW Amarok Double tube side step

Visual / Graphic Illustration	Step #	Description/Method
	<p style="text-align: center;">Step 1</p>	<p>Fig 1 shows which holes to use on the passengers side of the chassis. Fig 1 also gives you a quick guide to what each hole is going to take.</p>
	<p style="text-align: center;">Step 2</p>	<p>Fig 3 shows you how to mount the T-bolts and how to use the velomoid to avoid dropping it into the chassis.</p>
	<p style="text-align: center;">Step 3</p>	<p>Fig 2 shows how the Front bracket is mounted from the inside of the chassis, brackets are marked D for driver side and P for Passenger side.</p>
	<p style="text-align: center;">Step 4</p>	<p>FIG 1 shows how to mount all brackets and what kit to use. Do not fully tighten as adjustment will be needed to fit the side bars.</p>

Fitment Instruction:
VW Amarok Double tube side step

Visual / Graphic Illustration

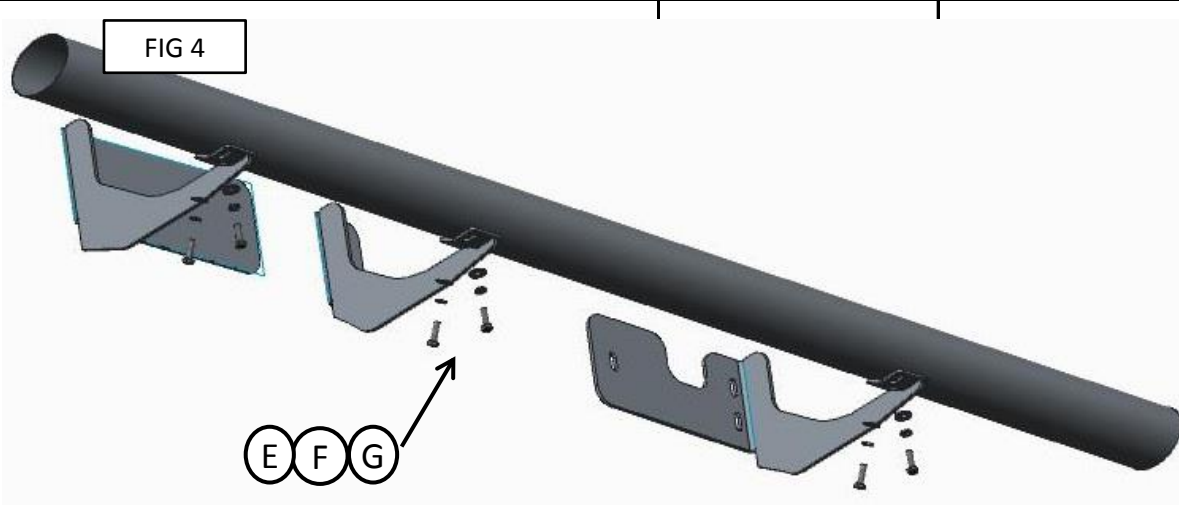

Step #

Description/Method

Step 5

FIG 4 shows how to mount the steps to the brackets , once aligned you can tighten all bolts.

Final step

Page 4 of 4

Make sure bar is centralised and tighten all fasteners to specified torque. M8= 22Nm , M10= 42Nm , M6= 9Nm.

