

# ACCESSORY FITMENT INSTRUCTION

**Product**

Toyota Hilux Fleet Sports Bar SC/DC

**Part no.**

80012 (269)



40  
Minutes

Models : SC/DC

Page 1 of 5

Date : 23 JUL 2019

DIAGRAM

Kit content:

	Qty	Description		Qty	Description
A	1	Front Bar	K	2	M8x90 Sets
B	1	Rear Bar	L	2	M8 spring washer
C	2	Base plates	M	2	M8x25x2 Flat washer
D	2	Corner rubbers	N	6	M8 Nylock Nuts
E	2	Load spreader plates (small)	O	4	M10x30x2.5 Flat washer
F	2	Top join rubber	P	4	M10 Nylock nuts
G	2	Grommets	Q	10	M8x25 Sets
H	4	Foot rubbers	R	16	M8x25x1.5 Flat washers
I	2	T-Nuts	S	4	M8 Spring Washers
J	2	Load spreader plates (large)			

Additional equipment/Material needed for fitment :

Qty		Socket and Ratchet Set	Qty	White Marker(Any Colour )
		Spanner Set		ø10mm Drill Bit
		Centre Punch		Hand Drill

Precautions during fitment:

Ensure that you are wearing appropriate PPE for the Following Fitment

Do Not cause any Damage to the vehicle

Requires 2 People to Fit

Directions for use:

Read all instructions Carefully before Fitting!

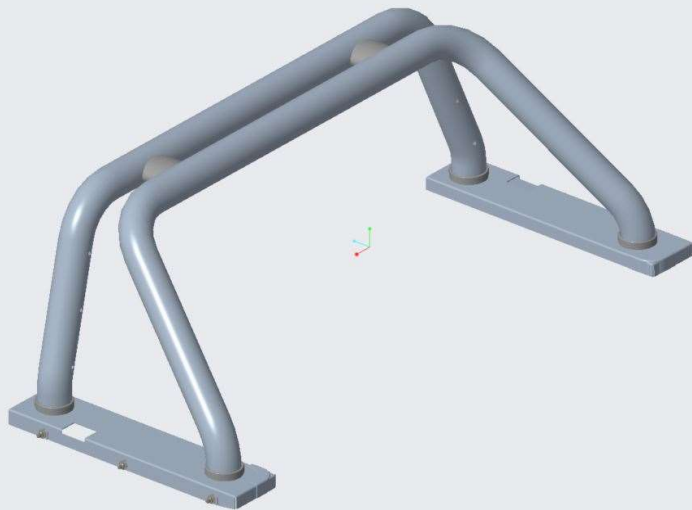

## Fitment Instruction: Toyota Hilux Fleet Sports Bar

Visual / Graphic Illustration

Step #

Description/Method

Figure 1

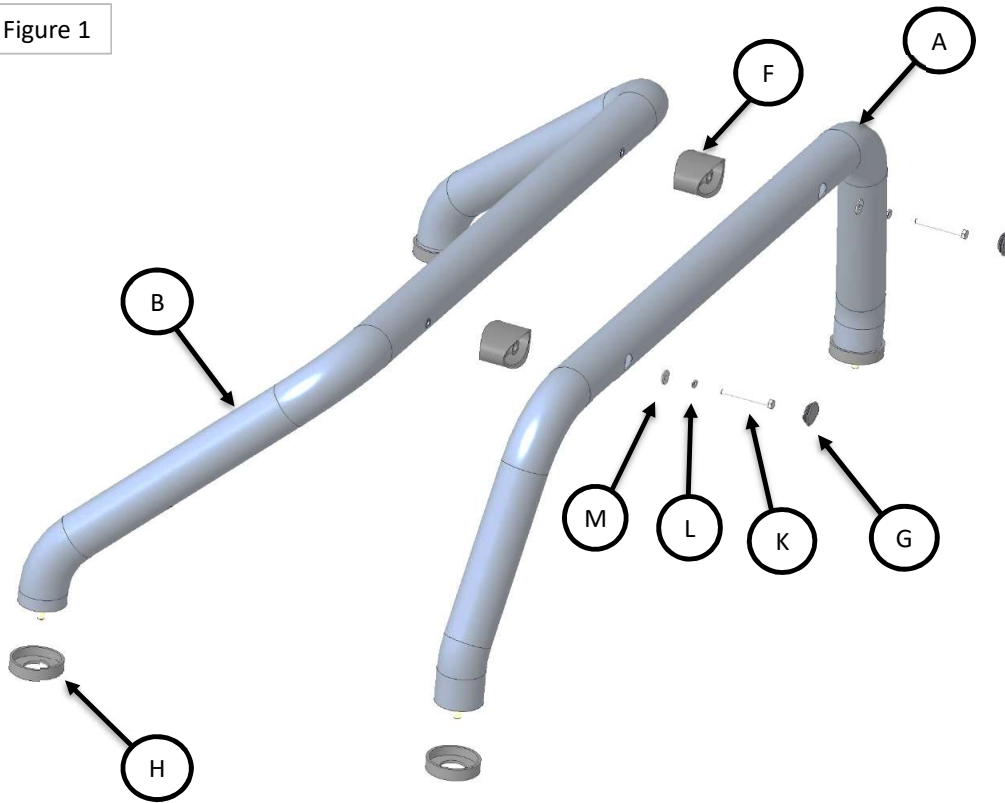
**1**

Assemble the Sports Bar as shown in Figure 1

**Fitment Instruction:**  
Toyota Hilux Fleet Sports Bar

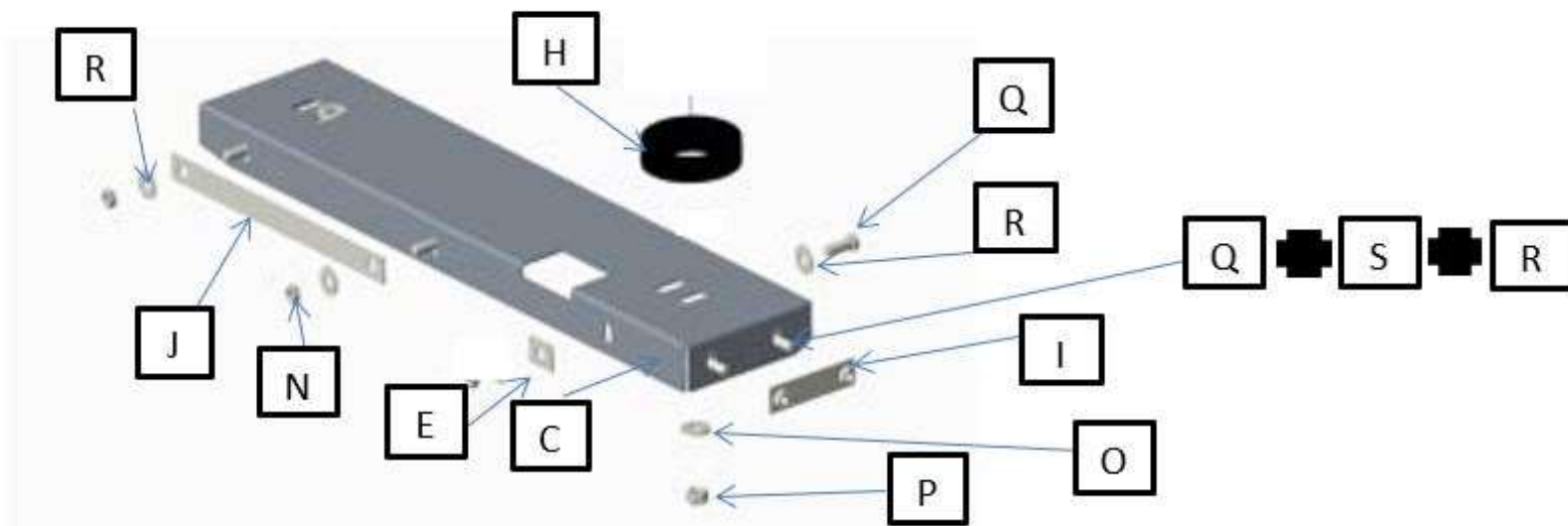
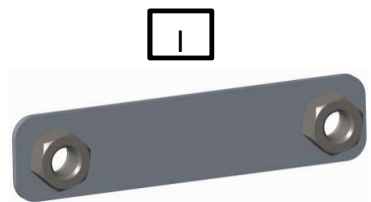

## Fitment Instruction: Toyota Hilux Fleet Sports Bar

Visual / Graphic Illustration



FIG 1.1

Apply tectyl to drilled holes

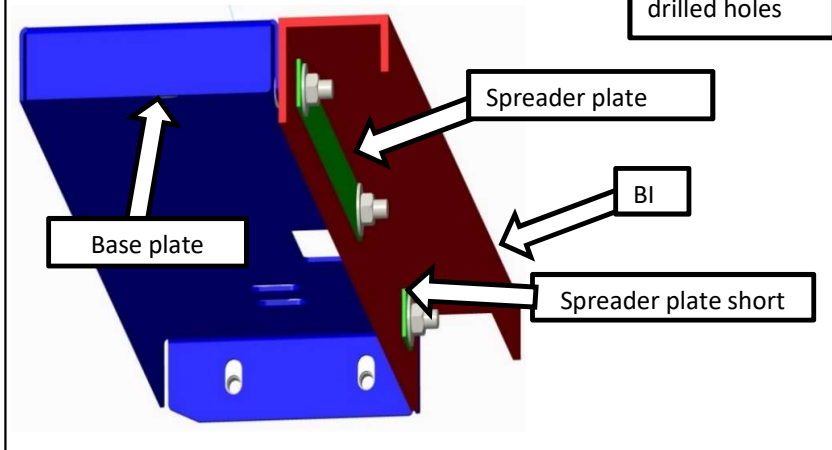

Step 1

Description/Method

Step 1.1

Place The base plate in the front corner of the bin, so that the holes in the base plate are on the bin side(as shown in fig 1.1). It would be a good idea to clamp the base plate down, so it does not move for the next step.

Step 1.2

Once the base plate is clamped, you will need to mark the locations that you will need to drill. You must mark the bin using the centre of the holes on the base plates

Step 1.3

Centre punch the centre of the mark you made in the previous step to keep it accurate. Once centre punched you must drill through the bin plate using a 9mm drill bit.

Step 1.4

You can now bolt the base plates onto the bin using the holes you have just drilled. The required bolts and nuts are shown on PAGE 3. The front of the base plate uses a special t-nut as there is no space for a spanner.

## Final step

Page 5 of 5

Make sure bar is centralised and tighten all fasteners to specified torque. M8= 22Nm , M10= 42Nm , M6= 9Nm.

