

# ACCESSORY FITMENT INSTRUCTION

**Product**

Triton L200 Facelift Sports Bar

**Product No:**

MIT-TRL2FL-SBS, MIT-TRL2FL-SBB , 30072T TN : 335



60  
Minutes

Models : Dcab

Page 1 of 5

Date : 15-04-2019

DIAGRAM



Kit content:

	Qty	Description		Qty	Description
A	2	M8x90 Set	L	2	Top rubbers
B	18	M8x22x1.6 Flat washer	M	4	Feet rubbers
C	10	M8x25 Sets	N	2	grommet
D	6	M8 Hex nuts	O	2	Corner rubbers
E	12	M8 spring washers	P	1	Front bar
G	4	M10 Hex nuts	Q	1	Rear bar
H	4	M10 Spring washers	R	2	Side Tubes
I	4	M10x40x3 Flat washers			
K	2	Base plates LHS + RHS			

Additional equipment/Material needed for fitment :

Qty		Qty	
1	Spanner Set + extension	1	drill
1	Screw driver set	1	9mm Drill bit
1	Torque wrench	1	tectyl
		1	Centre punch

Precautions during fitment:

Ensure you have an adequate working space. Requires two people for fitment. Ensure that the correct tools and appropriate clothing are used with installation.

# Fitment Instruction: TRITON SPORTS BAR

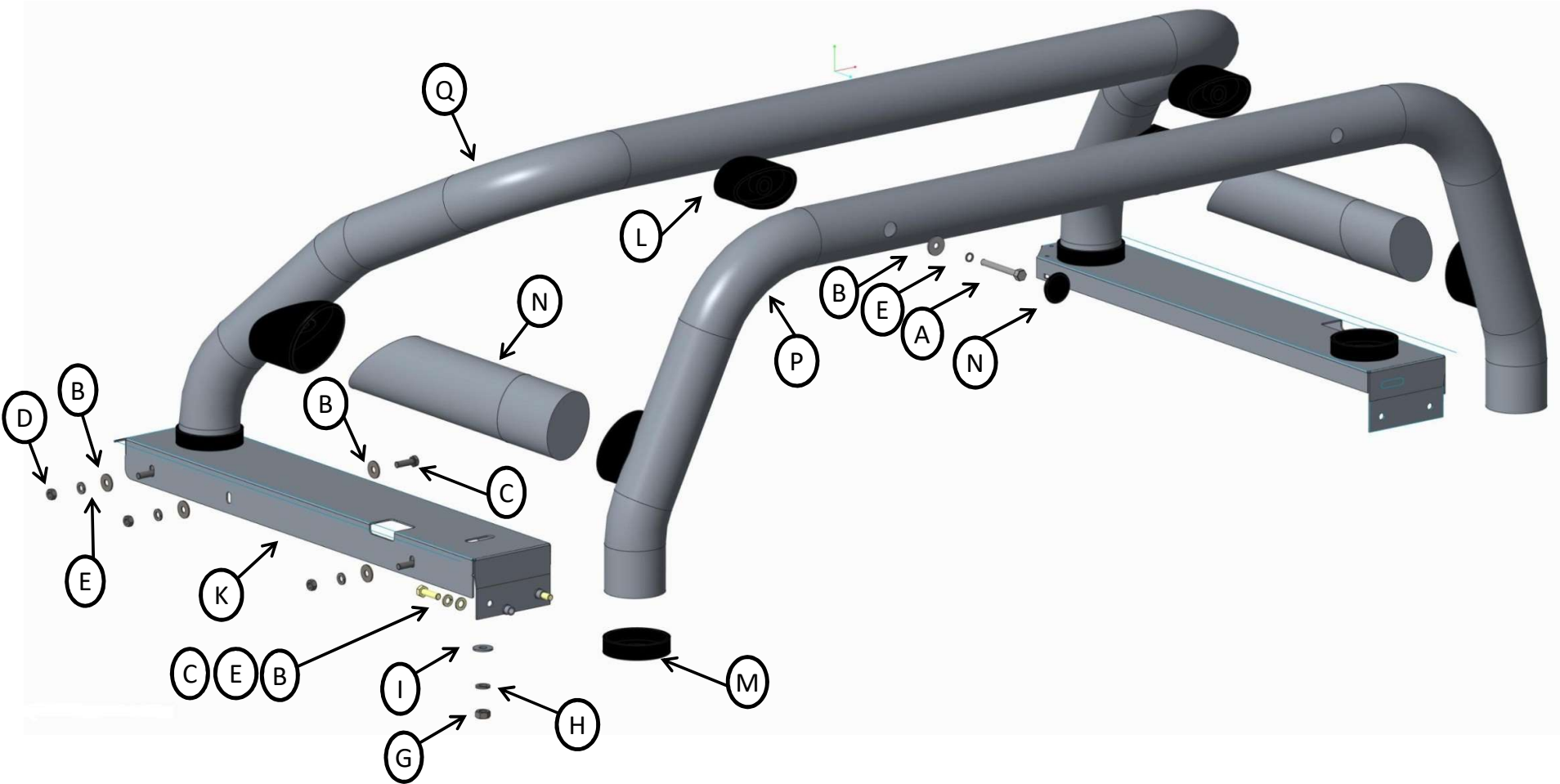

## Fitment Instruction: TRITON SPORTS BAR

Visual / Graphic Illustration



FIG 1.2

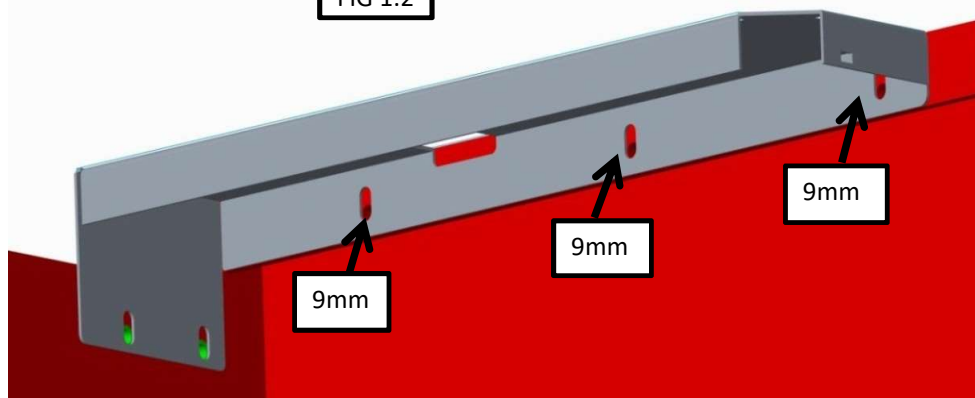

Step #

Description/Method

Step 1.1

Place The base plate in the front corner of the bin, so that the holes in the base plate are on the bin side(as shown in fig 1.1). It would be a good idea to clamp the base plate down, so it does not move for the next step. Repeat to other side of vehicle

Step 1.2

Once the base plate is clamped, you will need to mark the locations that you will need to drill FIG 1.2. You must mark the bin using the centre of the holes on the base plates. Repeat to other side of vehicle

Step 1.3

Centre punch the centre of the mark you made in the previous step to keep it accurate. Once centre punched drill the holes to the sizes specified FIG 1.2. Repeat to other side of vehicle

Step 1.4

Apply tectyl on the drilled holes. Repeat to other side of vehicle

**Fitment Instruction:**  
**TRITON SPORTS BAR**

Visual / Graphic Illustration

Step #

Description/Method

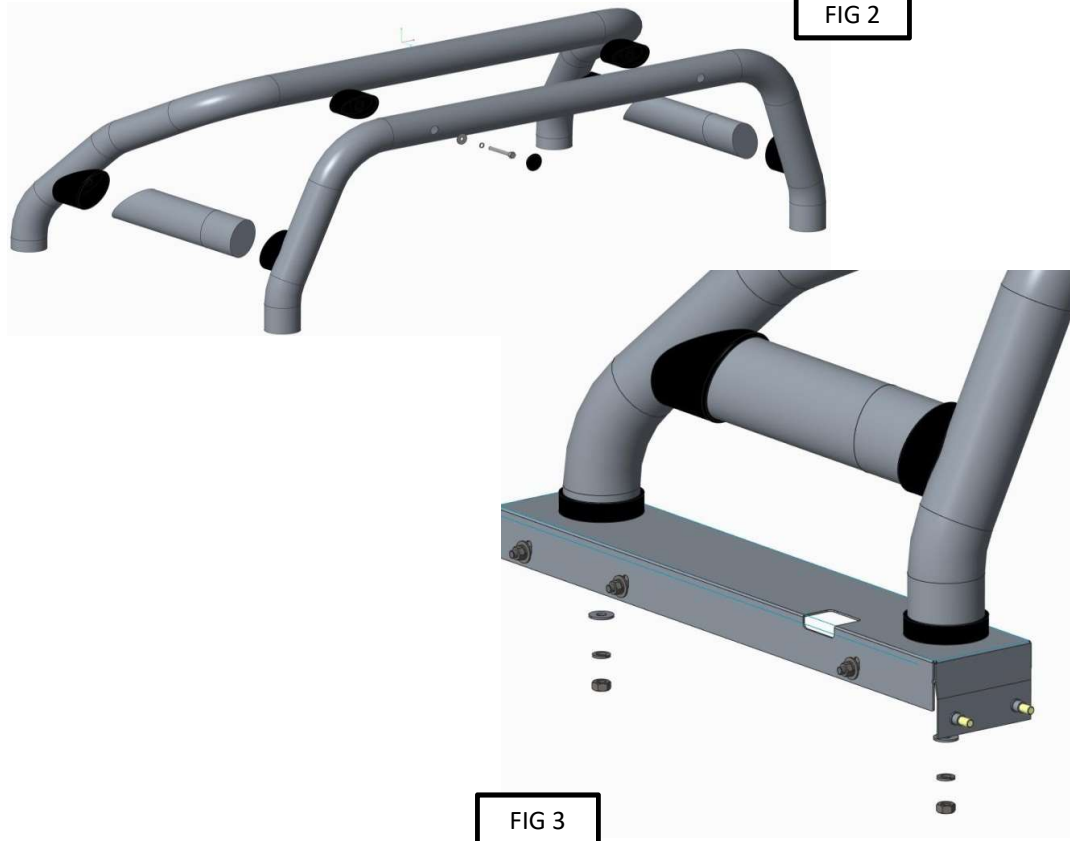

Step 2

Preassemble sports bar before mounting to base plates. FIG 2.

Step 3

Place sports bar onto base plates and tighten using the kit shown in FIG 3.

## Final step

Page 5 of 5

Make sure bar is centralised and tighten all fasteners to specified torque. M8= 22Nm , M10= 42Nm , M6= 9Nm.

