

ACCESSORY FITMENT INSTRUCTION

Product

Ford Ranger Next GEN Sports Bar

Part no.

150053 TN : 484



60
Minutes

Models : DCAB

Page 1 of 10

Date :26/01/2023

DIAGRAM



Kit content:

	Qty	Description		Qty	Description
A	4	M8x40mm Set screws	P	2	Rear Bracket (P+D)
B	8	M8x30mm Set screw	Q	2	M8 spreader plates
C	4	M6x25 Counter Sunk	R	4	tube spacers
D	6	M8x30x2.5mm Flast Washer	S	2	12 mm Spacers
E	2	M8x20mmx2.5mm Flat washer	T	2	16mm Spacers
F	12	M8 Spring washer	U	2	Securi Lid Brackets
G	6	M8 Plastic Caps	V		
H	4	M8 x 90 Set screws	W		
I	4	M8 x 20 x 2.5 flat washers	X		
J	4	M8 Spring washers	Y		
K	4	Joining Rubbers			
L	6	Grommets			
M	4	Front Base rubbers			
N	4	Rear base rubbers			
O	4	Front bracket (P+D)			

Additional equipment/Material needed for fitment :

Qty		Spanner Set + extension		Screwdriver set
		Torque wrench		Stanley knife
		Measuring Tape		Allen Key set

Precautions during fitment:

Ensure you have an adequate working space. Requires two people for fitment. Ensure that the correct tools are used with installation. Read through the fitting instructions carefully before installation.

Fitment Instruction: Ranger Sports Bar

Visual / Graphic Illustration

Step #

Description/Method

Assemble Sports Bar As Shown before installation

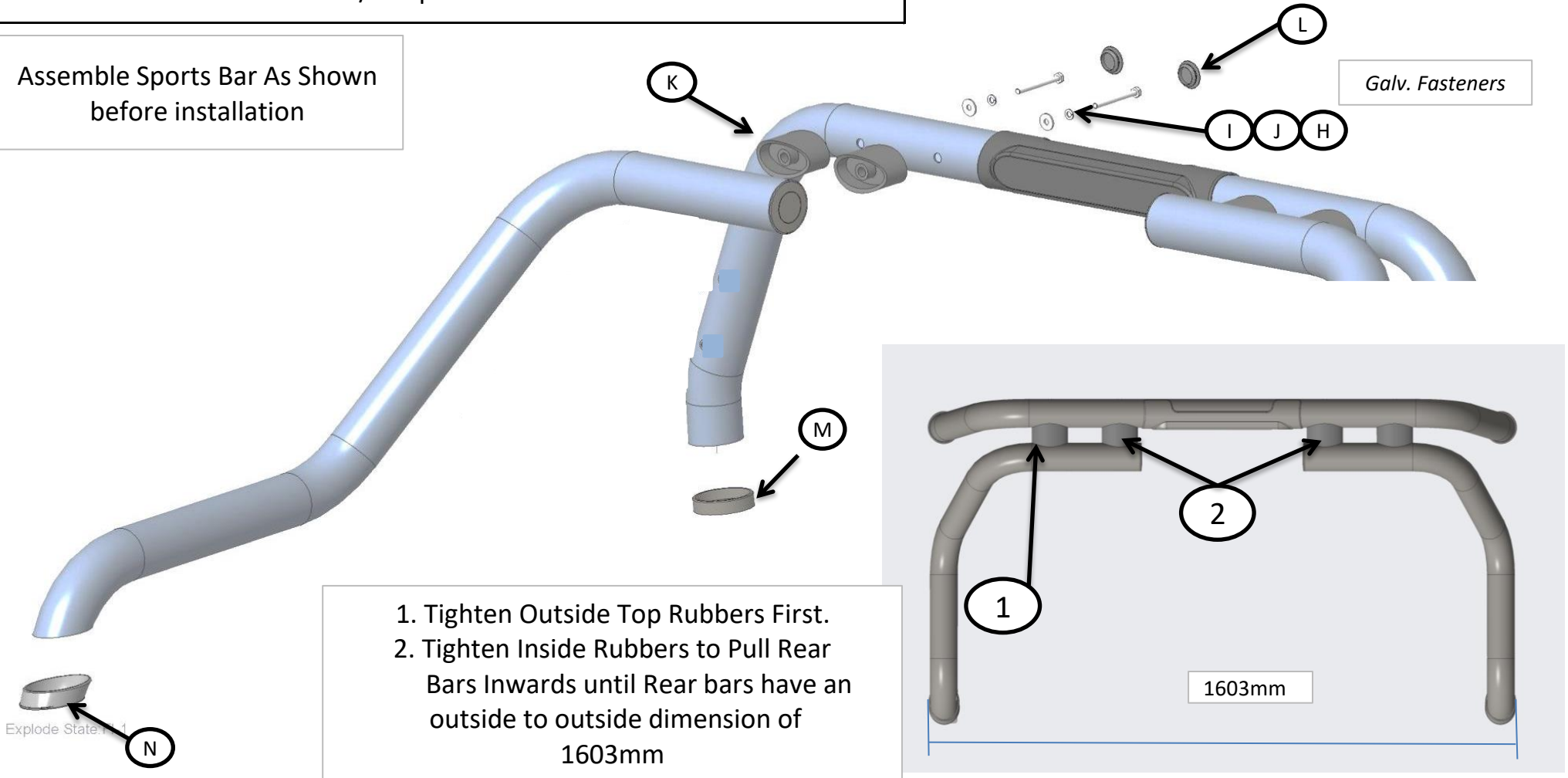

1. Tighten Outside Top Rubbers First.
2. Tighten Inside Rubbers to Pull Rear Bars Inwards until Rear bars have an outside to outside dimension of 1603mm

Fitment Instruction: Ranger Sports Bar

Visual / Graphic Illustration

Step #

Description/Method

Rear bars to Be Level with Front Bar before
Tightening Fully

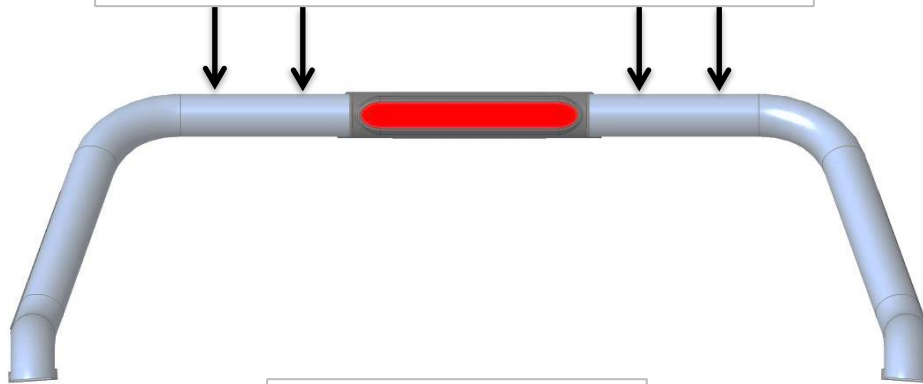

Rear View

Fitment Instruction: Ranger Sports Bar

Visual / Graphic Illustration

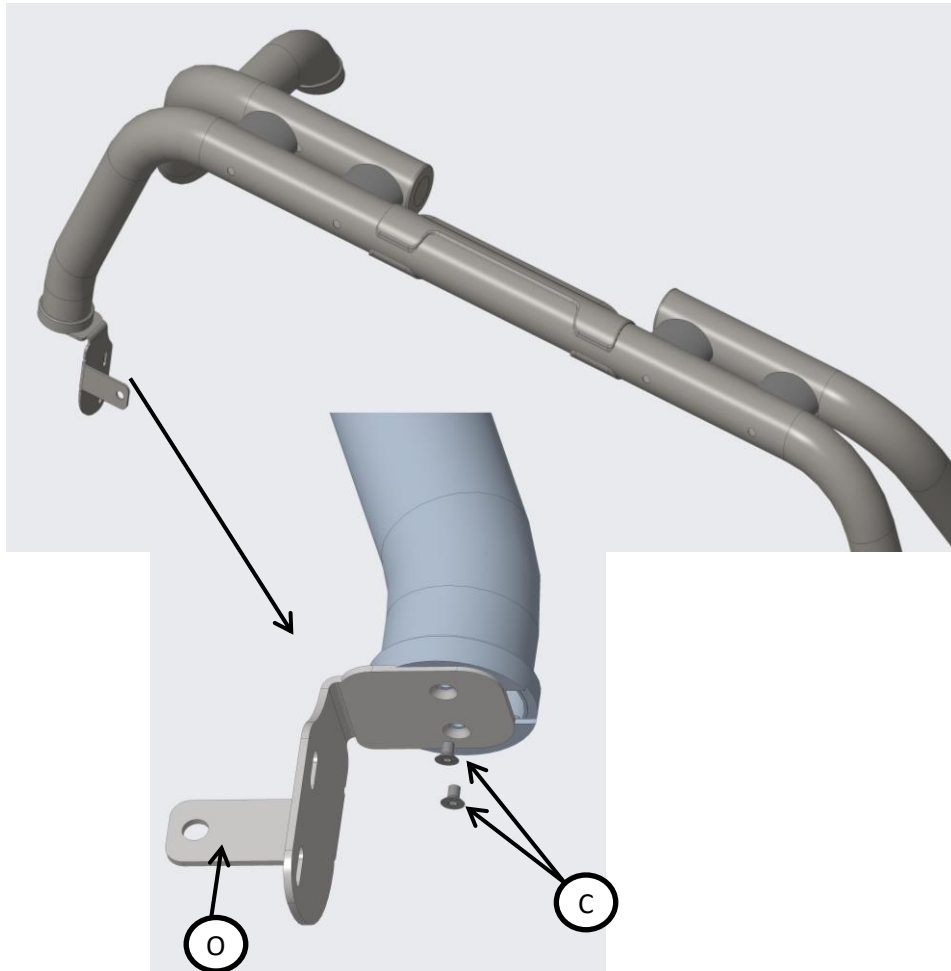

Step #

Description/Method

1

Securely mount the front brackets onto the bar using the fasteners provided.

Fitment Instruction: Ranger Sports Bar

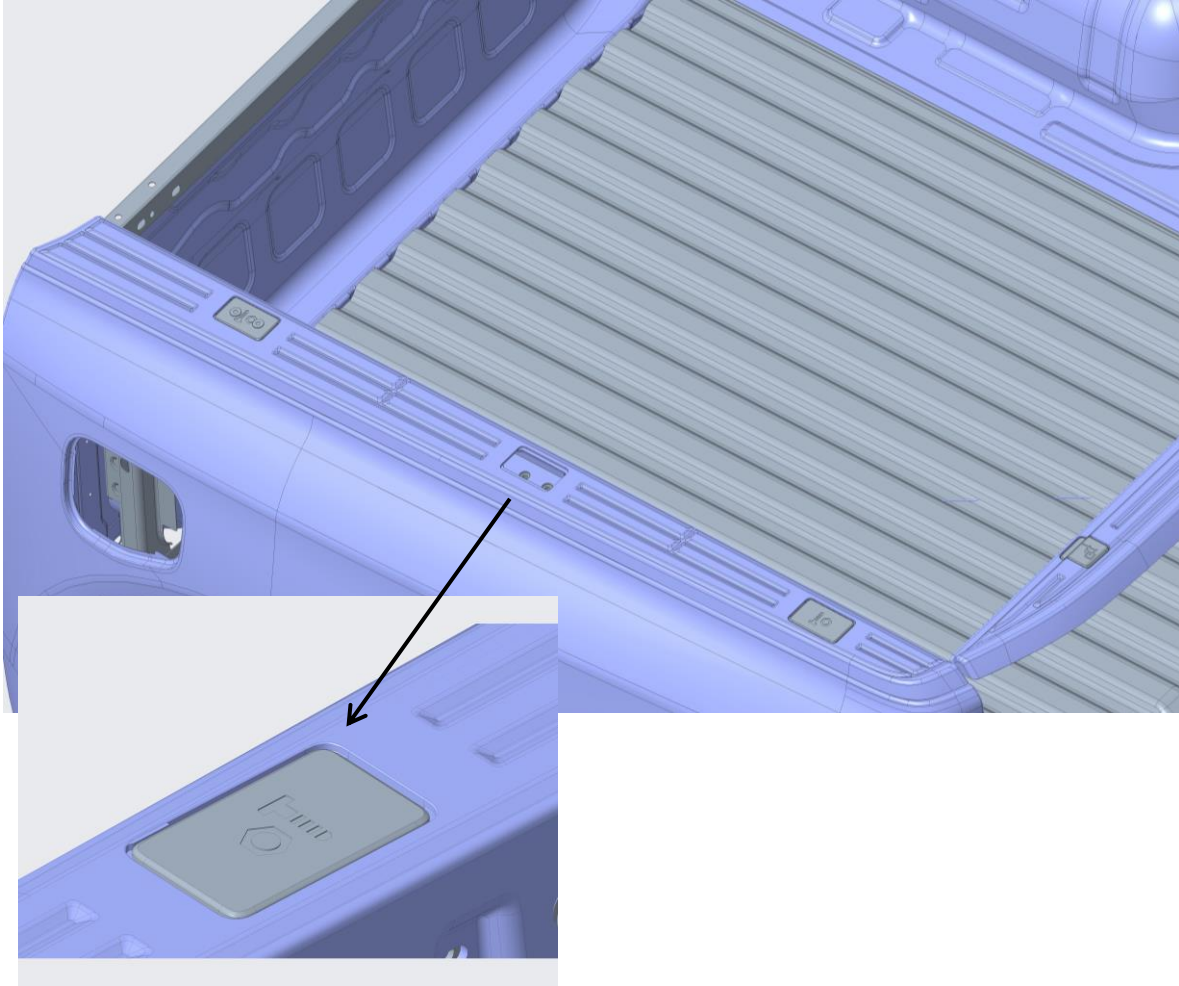
Visual / Graphic Illustration	Step #	Description/Method
	2	Gently remove the middle plastic cap to reveal to mounting holes underneath

Fitment Instruction: Ranger Sports Bar

Visual / Graphic Illustration

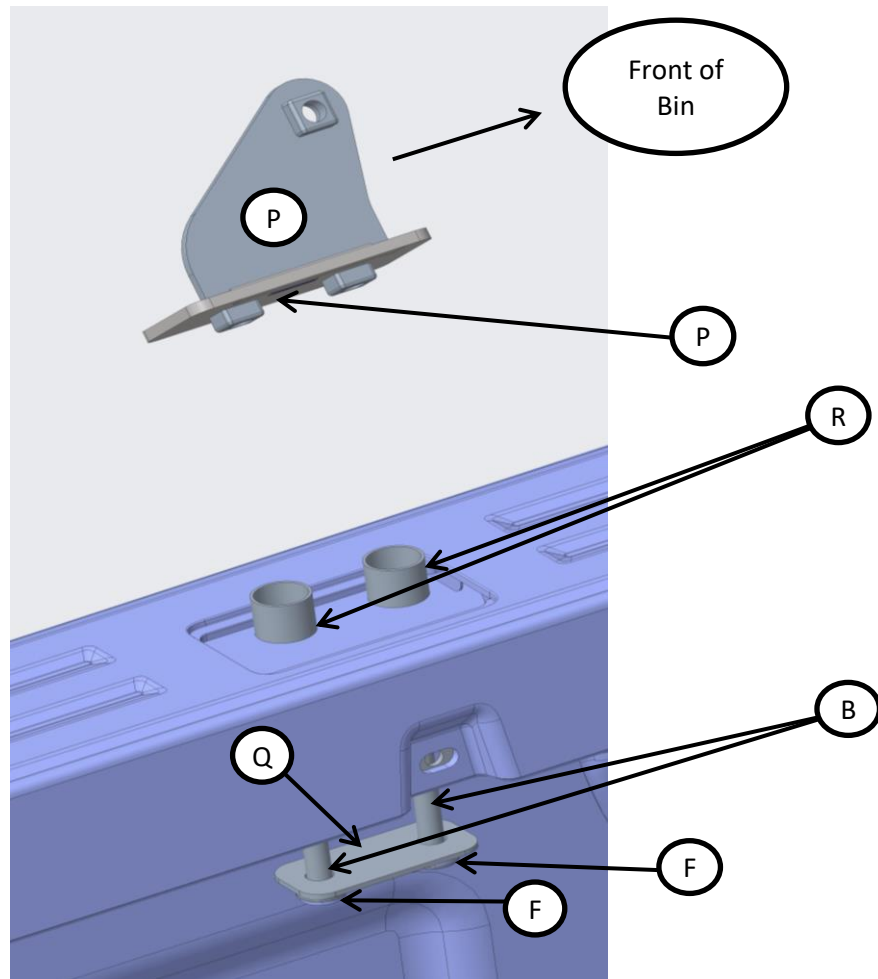

Step #

Description/Method

3

Place the tube spacers over the holes and then place the rear bracket over the spacers.

4

Using the M8 fasteners and the spreader plate provided secure the rear bracket from below as shown in the image.

NB

Bracket P must point towards the front of the Vehicle. Note that brackets will be marked with a P and D to help differentiate which side it will fit on.

Fitment Instruction: Ranger Sports Bar

Visual / Graphic Illustration

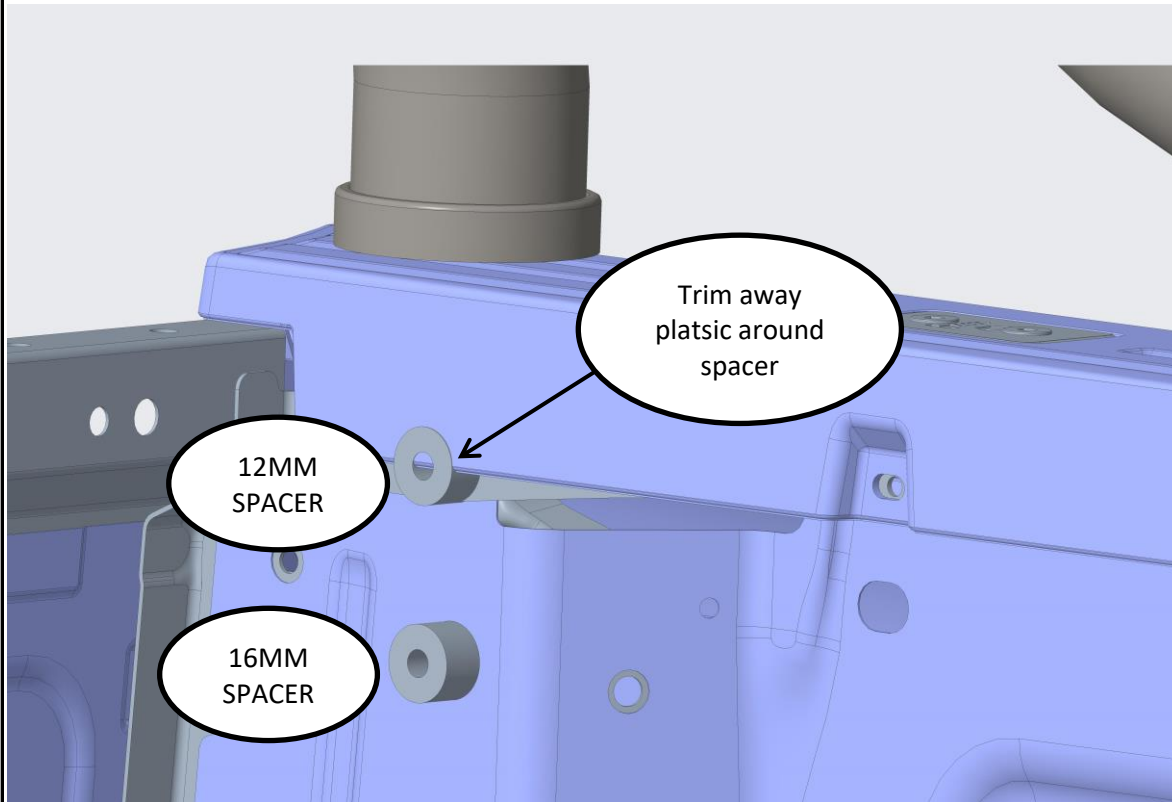

Step #

Description/Method

5

Using the 12 mm and 16 mm spacers provided, you can now mount the front bracket. Begin by making a slight trim around the 12mm spacer using a stanely knife. Once you are done the spacer should fits flush.

Fitment Instruction: Ranger Sports Bar

Visual / Graphic Illustration

Step #

Description/Method

6

Using the M8 fasteners provided, loosely mount the bracket in place.

7

There are black plastic caps provided to the bolt heads after the fitment has been completed.

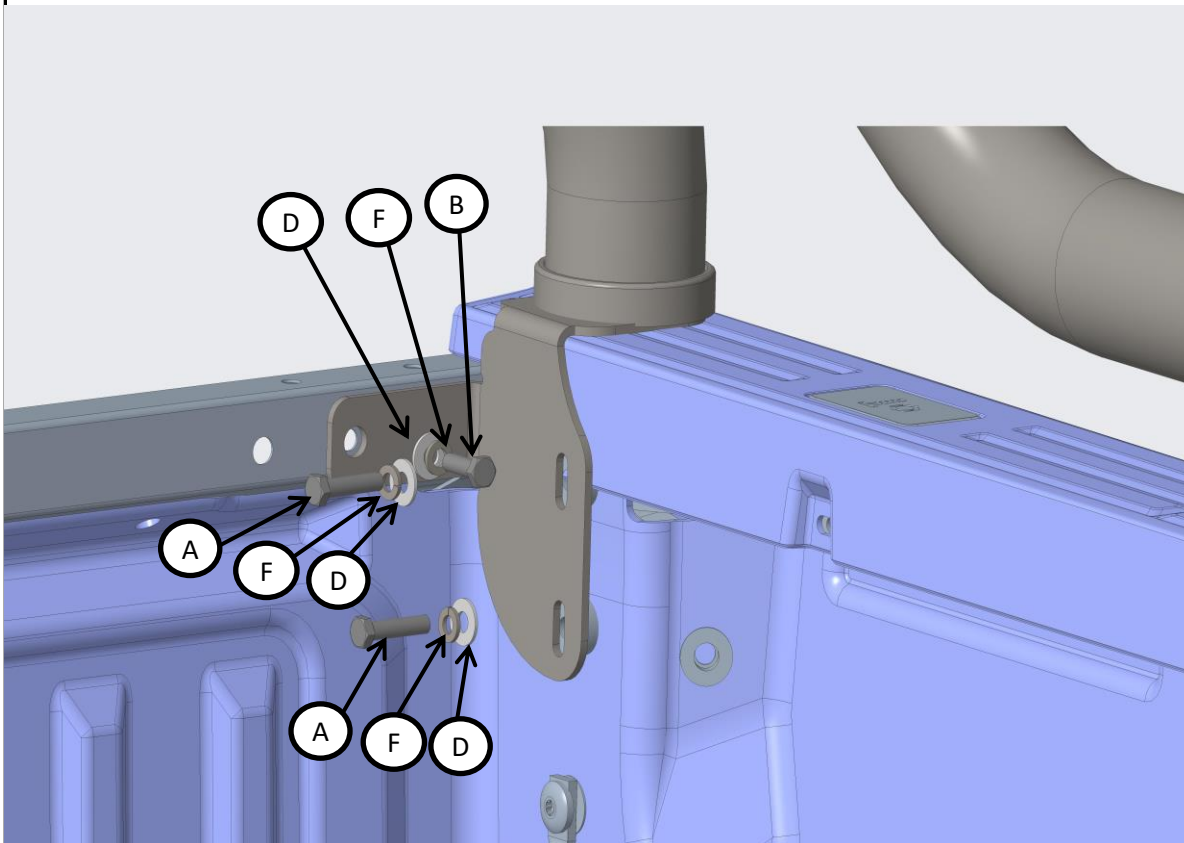

Fitment Instruction: Ranger Sports Bar

Visual / Graphic Illustration	Step #	Description/Method
	8	<p>Mount the rear leg onto the rear bracket using the M8 fastners, use the grommet to close off the hole once you have secured the bar at the end.</p>
	NB	<p>Care should be taken when lining up the rear leg (leg closest to the tailgate) to the mounting bracket. The bar must be completely flush before attempting to line up the mounting bolt. Should this be done incorrectly, you will not be able to adjust the bar once the mounting bolt is threaded.</p>

Final step

Page 10 of 10

Make sure bar is centralised and tighten all fasteners to specified torque. M8= 22Nm , M10= 42Nm , M6= 9Nm.

