

ACCESSORY FITMENT

Product

Ford Ranger Next GEN Sports Bar w Oval Side Tubes

Part no.

150055T & BS-150055



60
Minutes

Models : DCAB

Page 1 of 9

Date :21/09/2023

DIAGRAM



Kit content:

	Qty	Description		Qty	Description
A	4	M8 x 25 Sets	P	1	Passenger side corner Bracket
B	18	M8 x 20 x 1.6 Flat washers	Q	1	Drivers side Corner Bracket
C	18	M8 Spring washers	R	2	12mm Spacers
D	8	M8 Hex nuts	S	2	16mm Spacers
E	8	M8 x 45 CSK set screws	T	6	M8 plastic caps
F	2	M8 x 90 Set screws	U	8	CSK black caps
G	2	M8 x 25 x 2 Flat washers	V		
H	6	Grommets	W		
I	2	Base plates (P & D)	X		
J	4	Load spread plates	Y		
K	2	Top mount joining rubbers			
L	2	Side tubes			
M	4	Base rubbers			
N	8	Spacer tubes			
O	6	M8 x 40 sets			

Additional equipment/Material needed for fitment :

Qty		Spanner Set + extension			Screwdriver set
		Torque wrench			Stanley knife
		Measuring Tape			Allen Key set

Precautions during fitment:

Ensure you have an adequate working space. Requires two people for fitment. Ensure that the correct tools are used with installation. Read through the fitting instructions carefully before installation.

Fitment Instruction: Ranger Sports Bar

Visual / Graphic Illustration

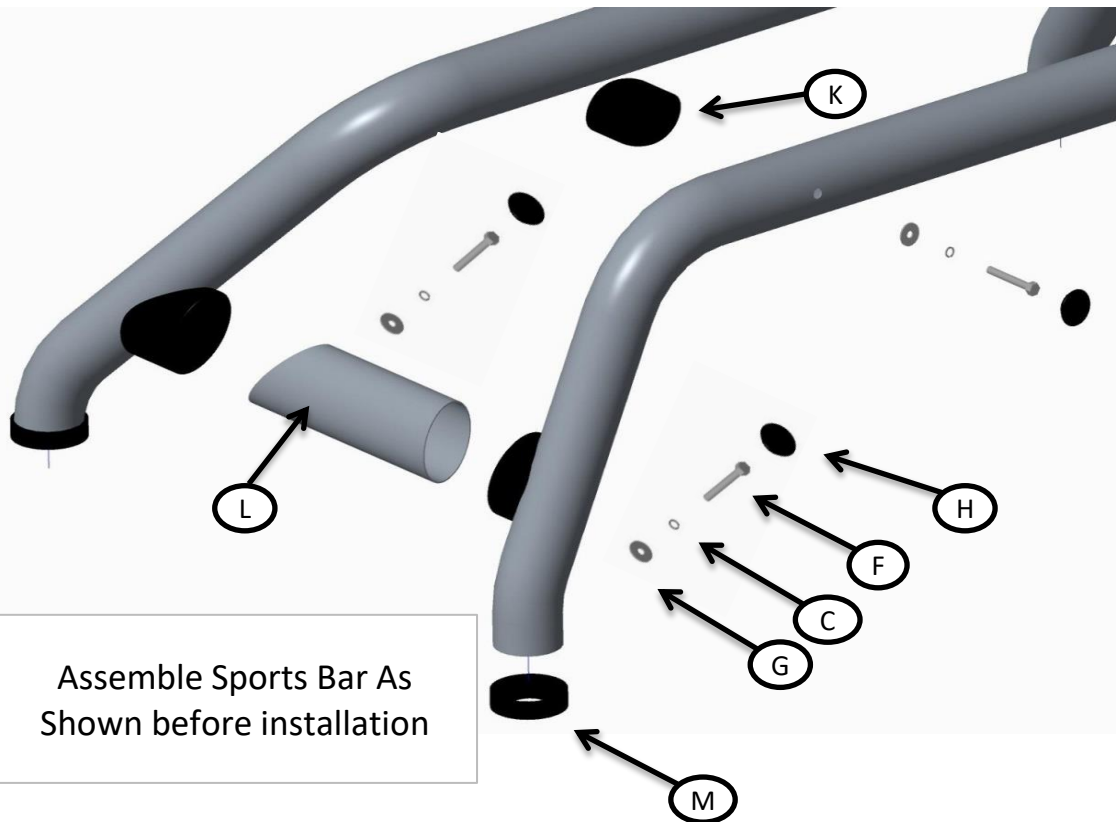

Step #

Description/Method

1

Assemble the sports bar using the fasteners provided.

Fitment Instruction: Ranger Sports Bar

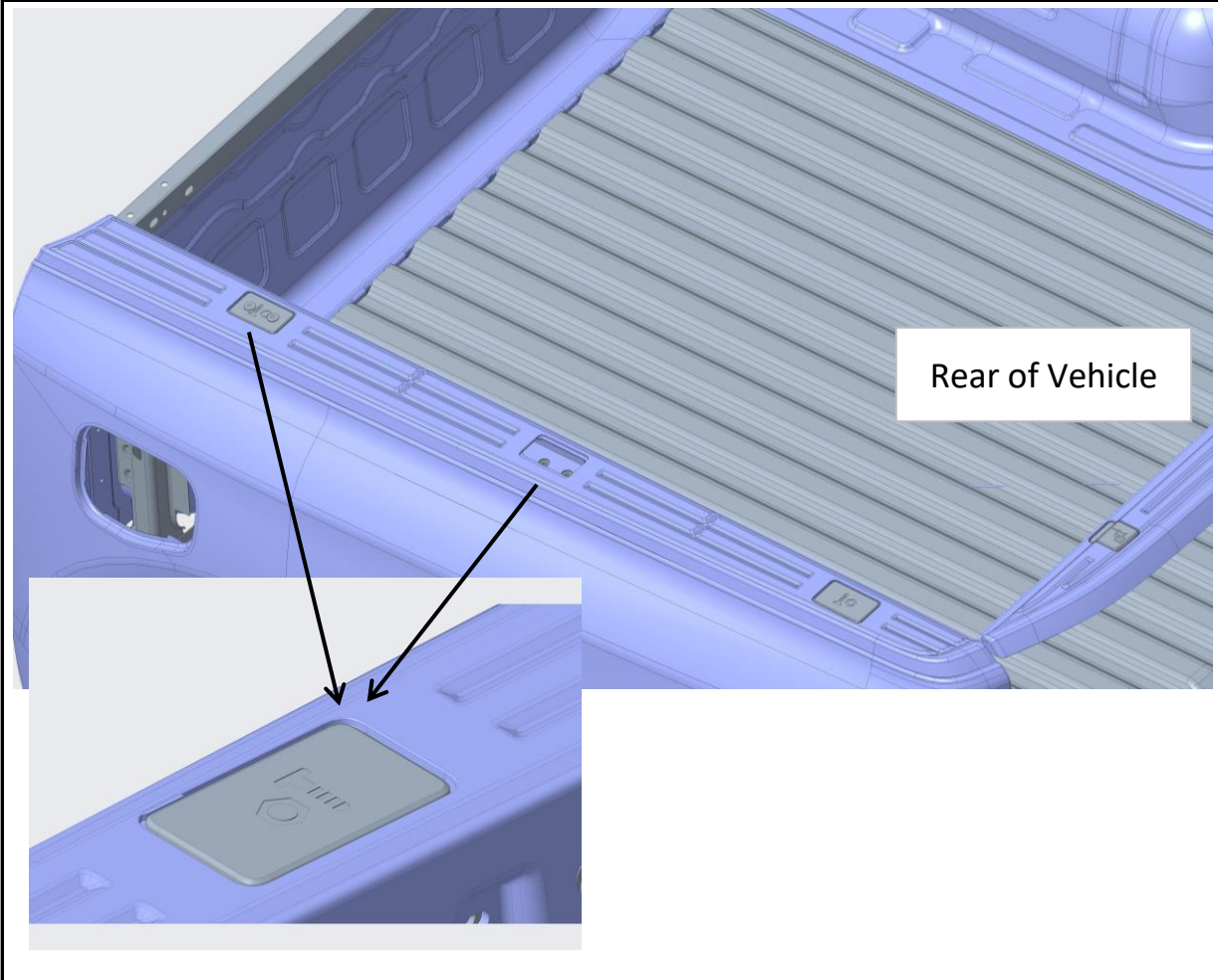
Visual / Graphic Illustration	Step #	Description/Method
	2	Gently remove the front and middle plastic cap to reveal to mounting holes underneath

Fitment Instruction: Ranger Sports Bar

Visual / Graphic Illustration

Step #

Description/Method

Fig 1

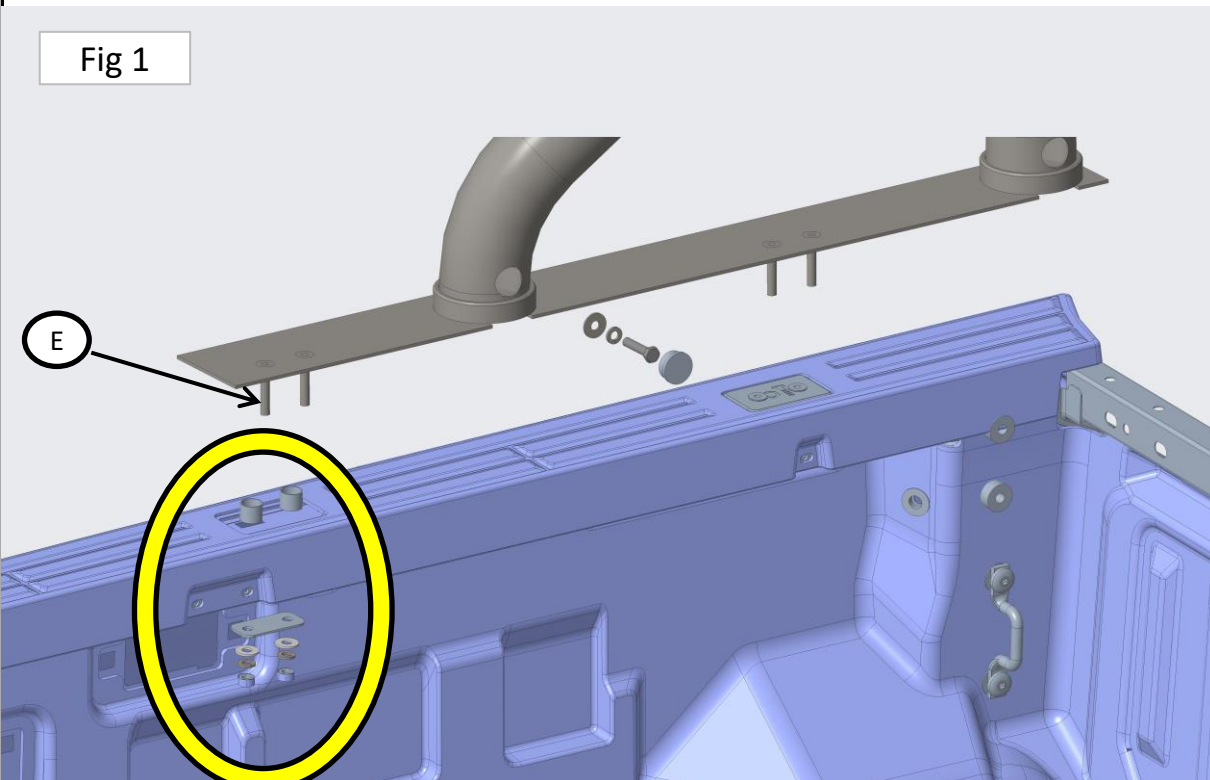

3

Loosely mount the Base Plate on to side using the hardware shown in Fig 1 and 2

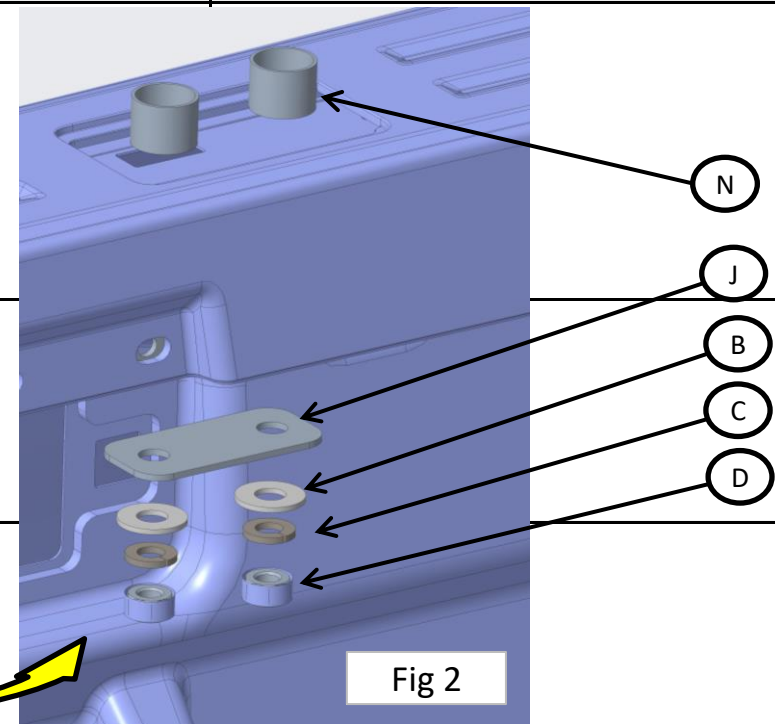
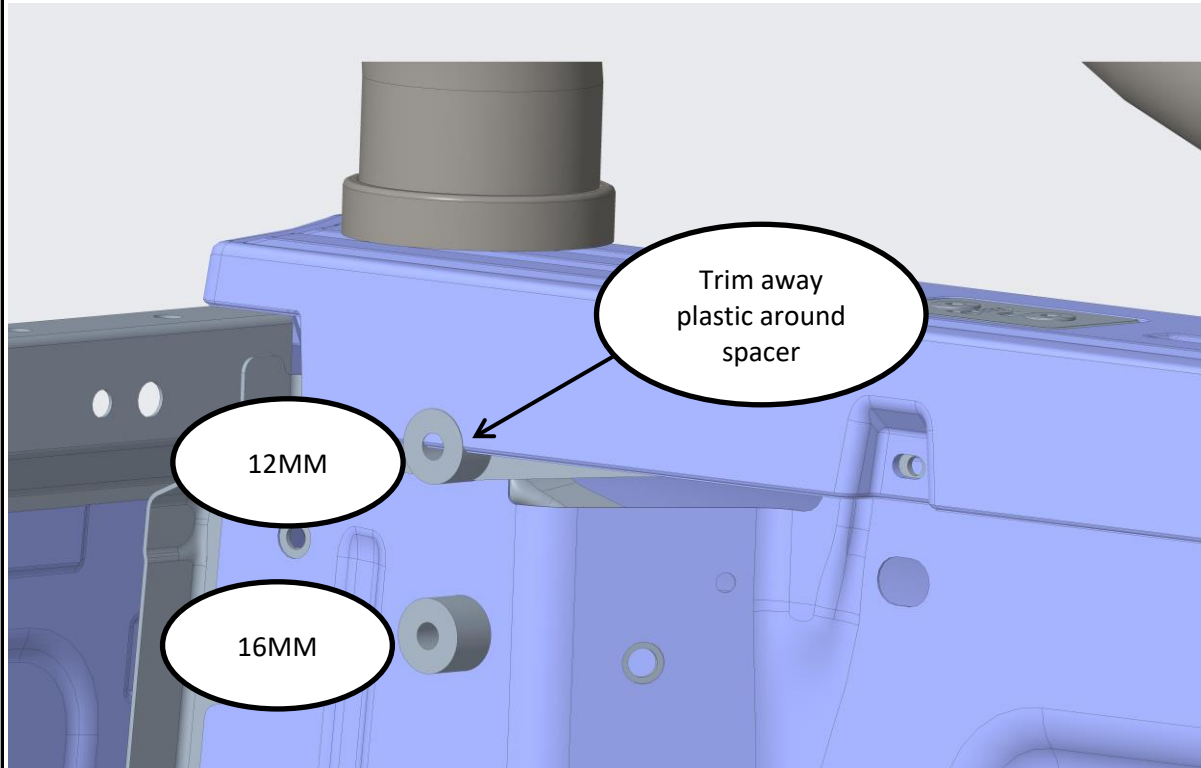

Fig 2

Fitment Instruction: Ranger Sports Bar

Visual / Graphic Illustration



Step #

Description/Method

4

Using the 12 mm and 16 mm spacers provided, you can now mount the front bracket. Begin by making a slight trim around the 12mm spacer using a Stanley knife. Once you are done the spacer should fit flush.

Fitment Instruction: Ranger Sports Bar

Visual / Graphic Illustration

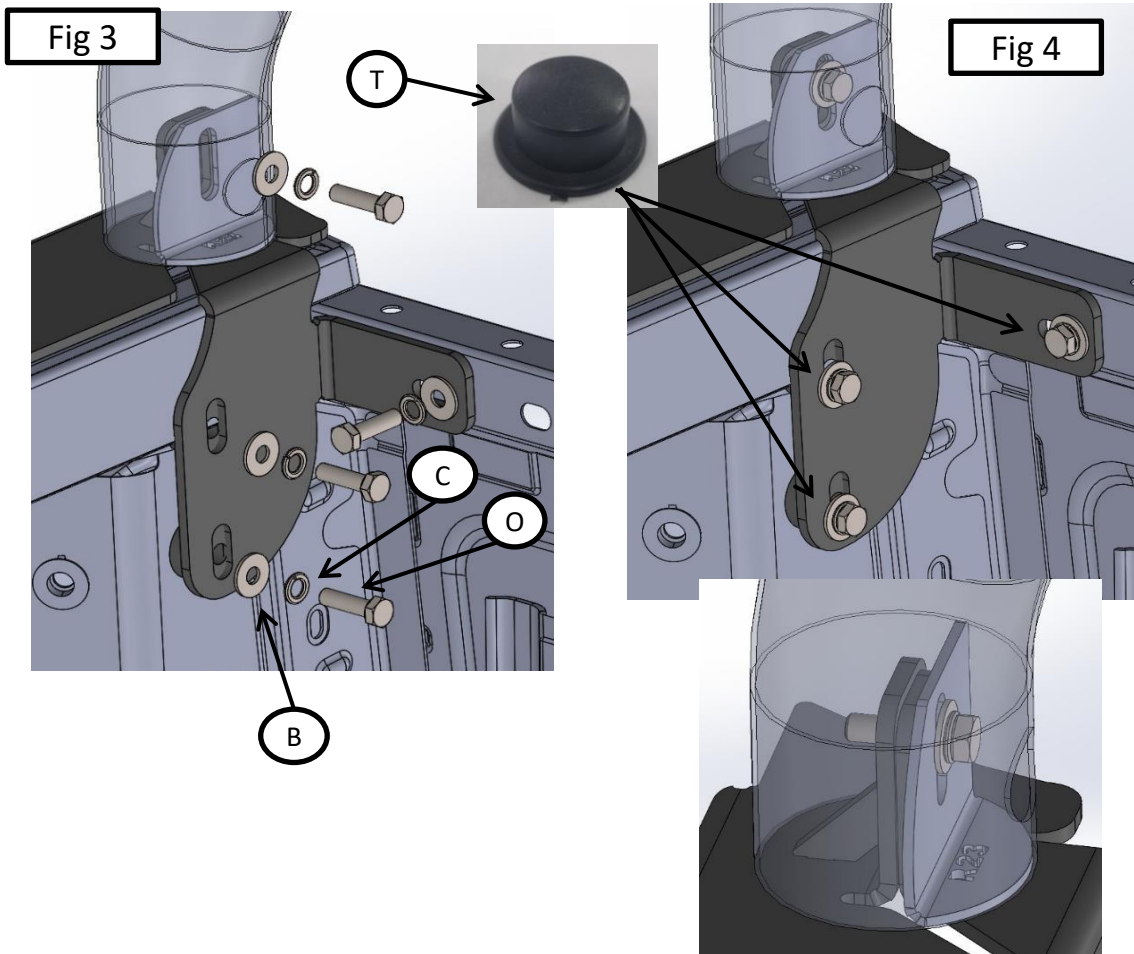

Step #

Description/Method

5

Install the Corner Brackets as shown in Fig 3 & 4. (Passenger side shown) Do not Tighten Fully yet. The M8 Bolt Cap (T) will only be required at the end of the fitment, after you have the bar secured.

Fitment Instruction: Ranger Sports Bar

Visual / Graphic Illustration	Step #	Description/Method
	<p>6</p>	<p>Once the base plate has been loosely mounted, place the assembled bar onto the base and using the fasteners below, loosely mount the entire bar to the base plates. The grommet(H) and the CSK cap(U) will only be required at the end of the fitment, after you have the bar secured.</p>

Fitment Instruction:
Ranger Sports Bar

Visual / Graphic Illustration

Step #

Description/Method



7

Once the bar is placed correctly, you can begin to tighten the base plate first, then tighten the bar onto the base plate.

8

Do not forget to fit the grommets(H) into the bar.

Make sure bar is centralised and tighten all fasteners to specified torque. M8= 22Nm , M10= 42Nm , M6= 9Nm.

