

ACCESSORY FITMENT INSTRUCTION

Product

Sports Bar - Standard Sports Bar Short Leg (Black)
(Raptor)

Part no.

150059 TN : 492



60
Minutes

Models : DCAB

Page 1 of 9

Date :04/10/2023

DIAGRAM



Kit content:

	Qty	Description		Qty	Description
A	12	M8 x 25 Sets	P	6	M8 x 40 sets
B	26	M8 x 20 x 1.6 Flat washers	Q	6	M8 plastic caps
C	28	M8 Spring washers	R	8	CSK black caps
D	8	M8 Hex nuts	S		
E	8	M8 x 45 CSK set screws	T		
F	2	M8 x 90 Set screws	U		
G	2	M8 x 25 x 2 Flat washers	V		
H	6	Grommets	W		
I	2	Base plates (P & D)	X		
J	4	Load spread plates	Y		
K	2	Top mount joining rubbers			
L	2	Side tubes			
M	4	Base rubbers			
N	8	Spacer tubes			
O	2	Side plate (P & D)			

Additional equipment/Material needed for fitment :

Qty		Spanner Set + extension			Screwdriver set
		Torque wrench			Stanley knife
		Measuring Tape			Allen Key set

Precautions during fitment:

Ensure you have an adequate working space. Requires two people for fitment. Ensure that the correct tools are used with installation. Read through the fitting instructions carefully before installation.

Fitment Instruction: Ranger Sports Bar

Visual / Graphic Illustration

Step #

Description/Method

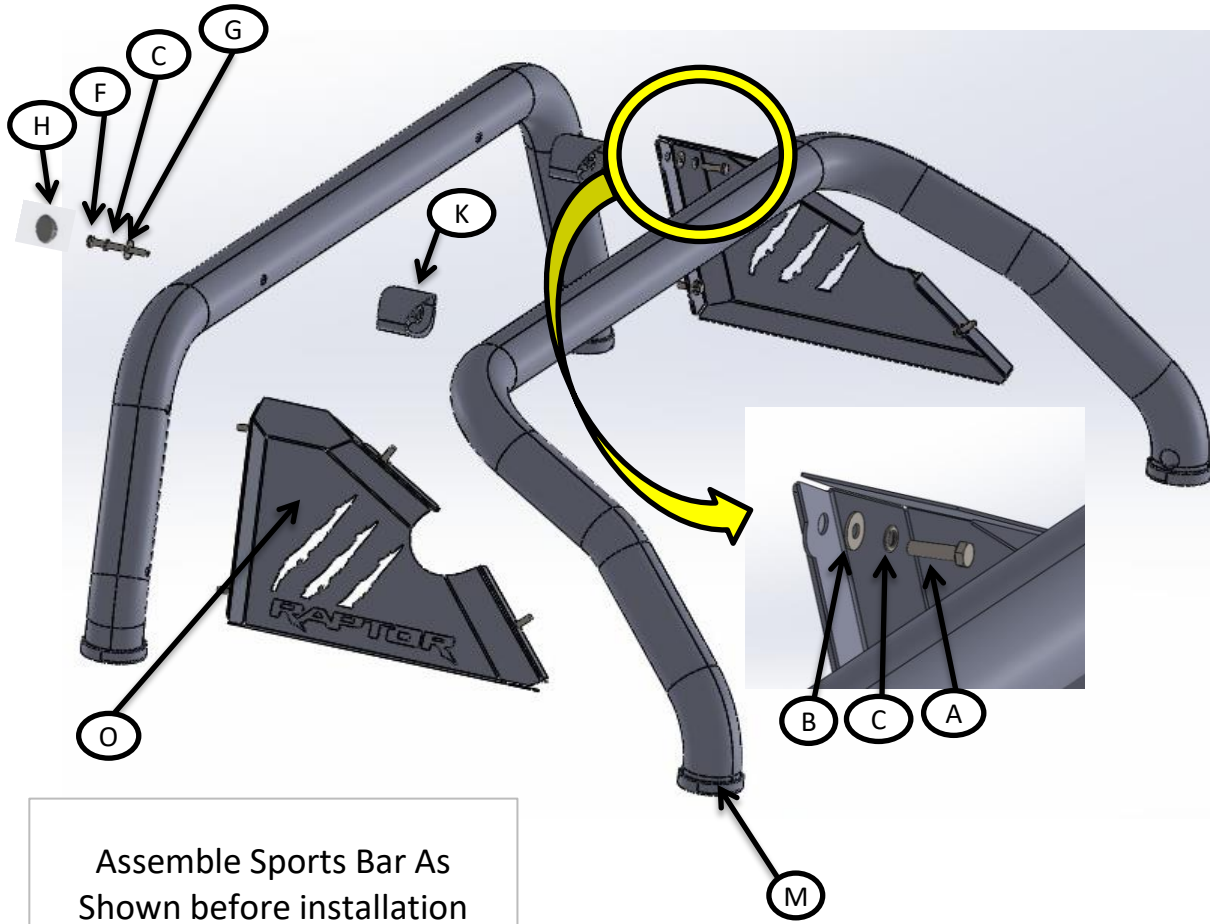

1

Assemble the sports bar using the fasteners provided.

Fitment Instruction: Ranger Sports Bar

Visual / Graphic Illustration

Step #

Description/Method

2

Gently remove the front and middle plastic cap to reveal mounting holes underneath

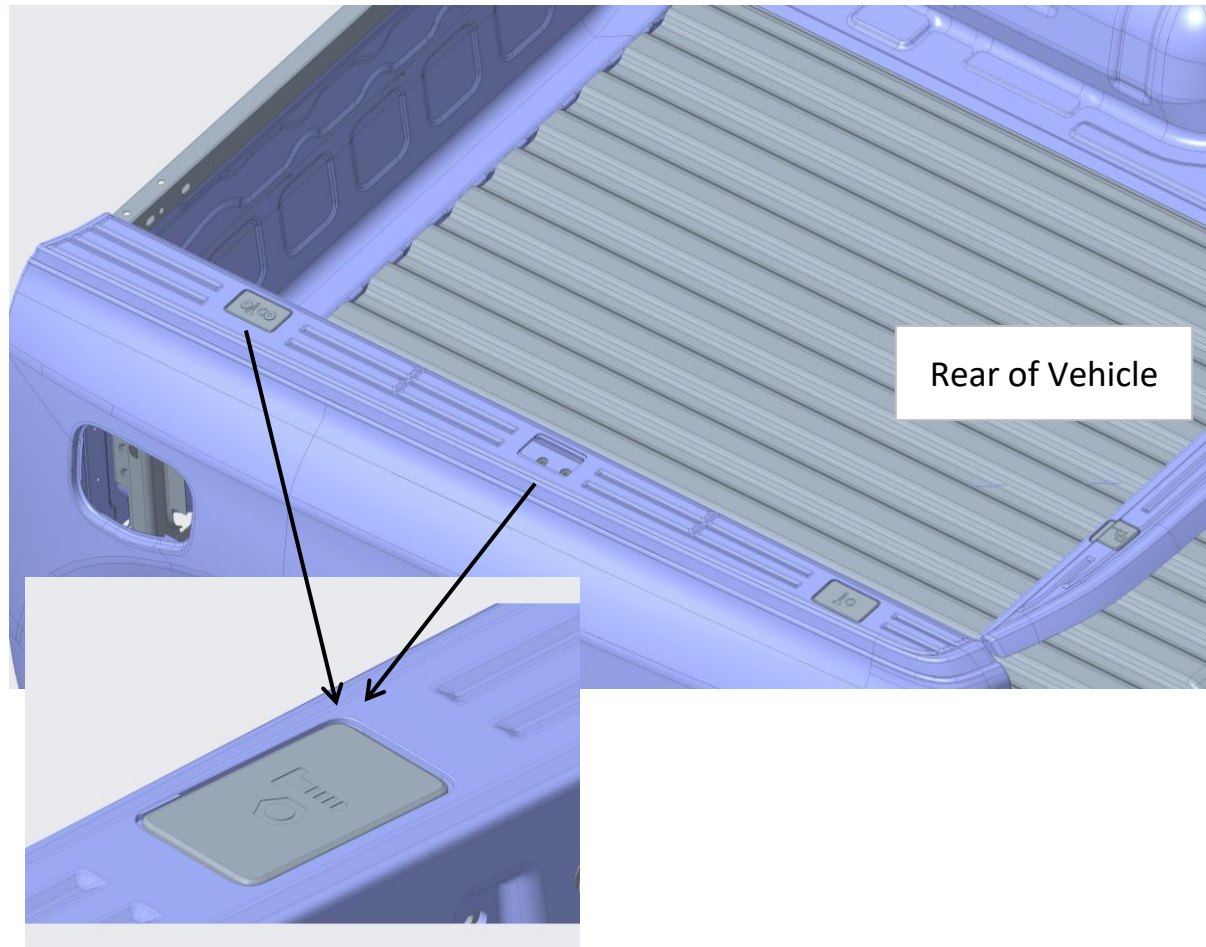

Rear of Vehicle

Fitment Instruction: Ranger Sports Bar

Visual / Graphic Illustration

Step #

Description/Method

Fig 1

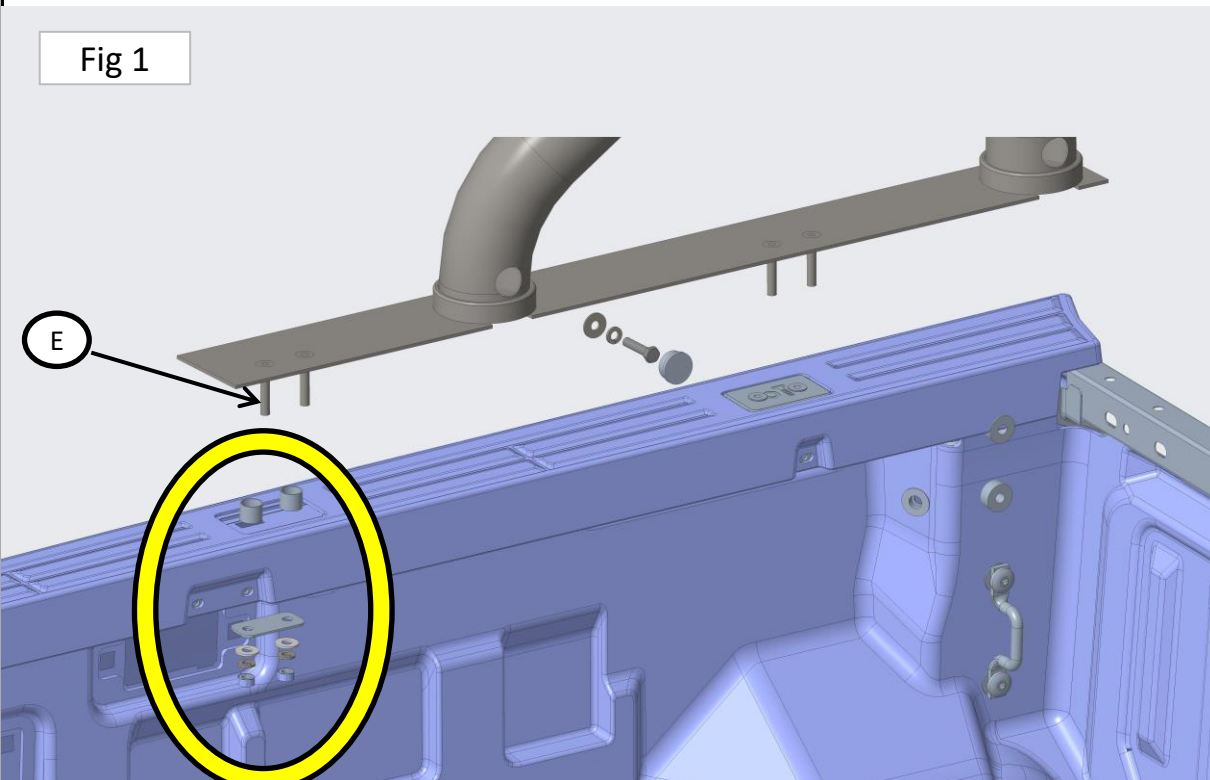

3

Loosley mount the Base Plate on to side using the hardware shown in Fig 1 and 2

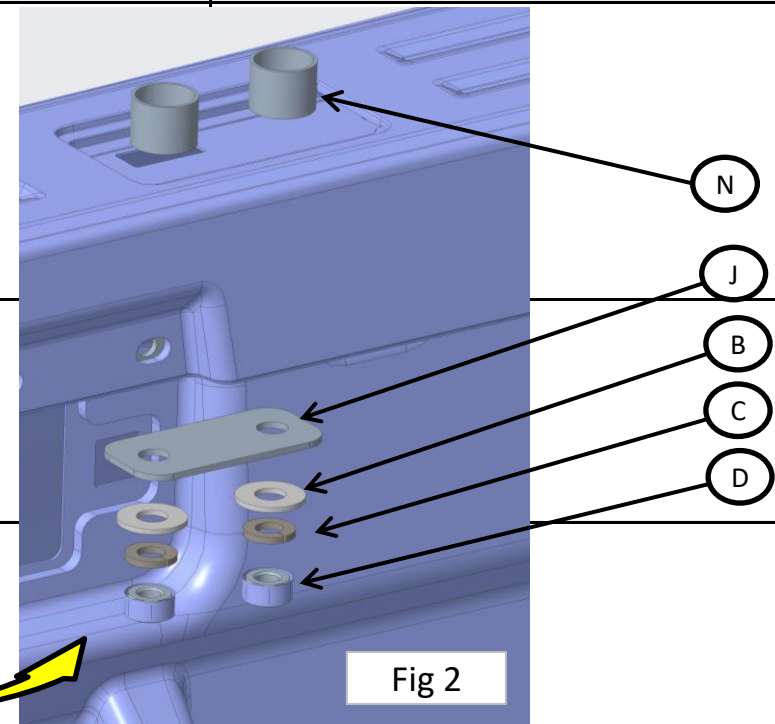

Fig 2

Fitment Instruction: Ranger Sports Bar

Visual / Graphic Illustration

Step

Description/Method

4

Using the 12 mm and 16 mm spacers provided, you can now mount the front bracket. Begin by making a slight trim around the 12mm spacer using a Stanley knife. Once you are done the spacer should fits flush.

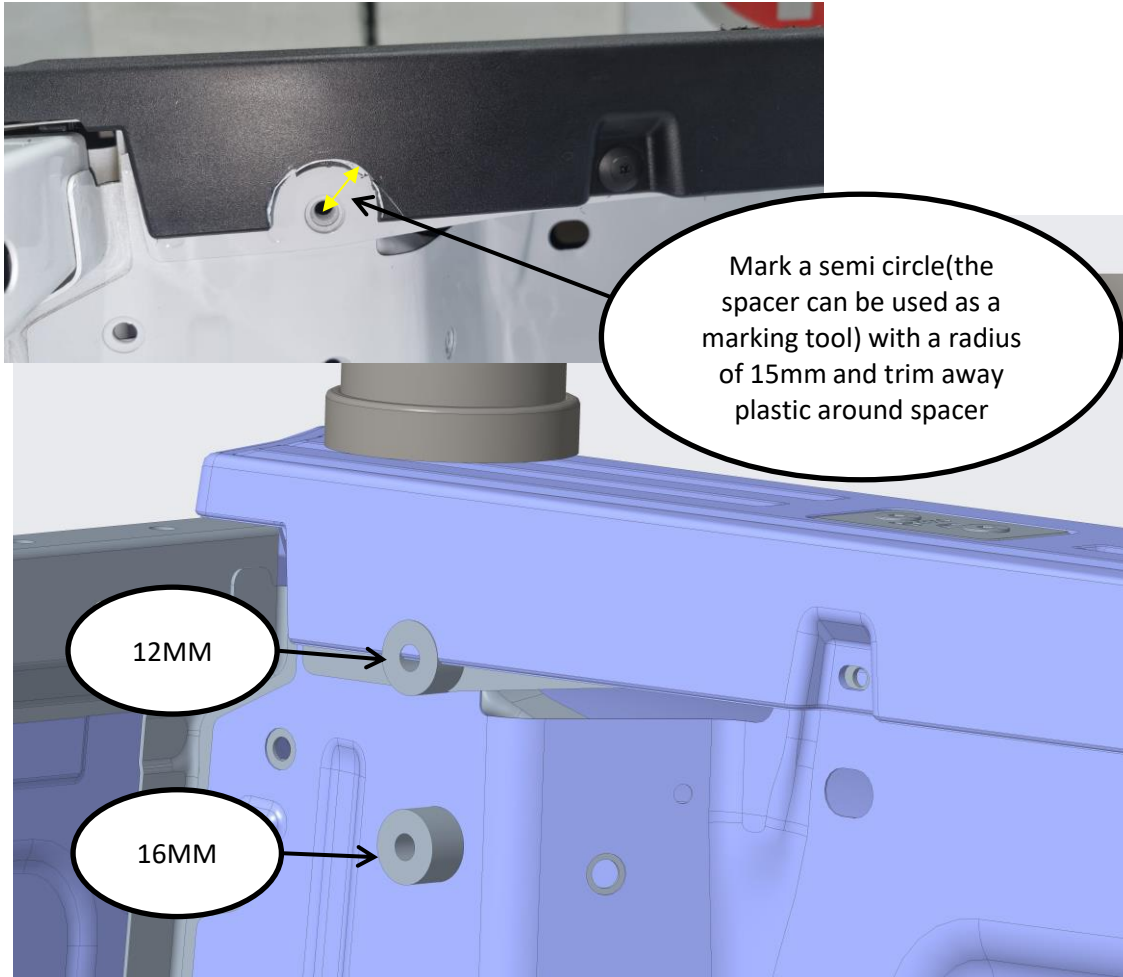

Fitment Instruction:

Ranger Sports Bar

Visual / Graphic Illustration

Step #

Description/Method

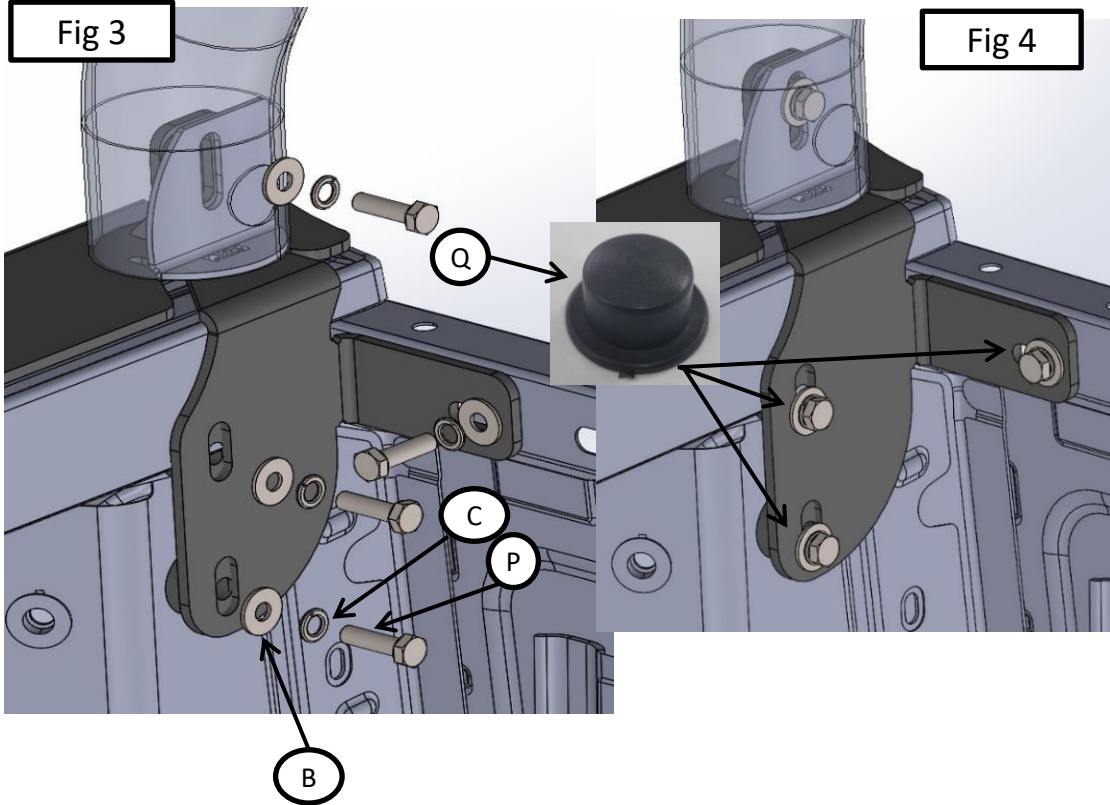

5

Install the Corner Brackets as shown in Fig 3 & 4. (Passenger side shown) Do not Tighten Fully yet. The M8 Bolt Cap(Q) will only be required at the end of the fitment, after you have the bar secured.

Fitment Instruction: Ranger Sports Bar

Visual / Graphic Illustration

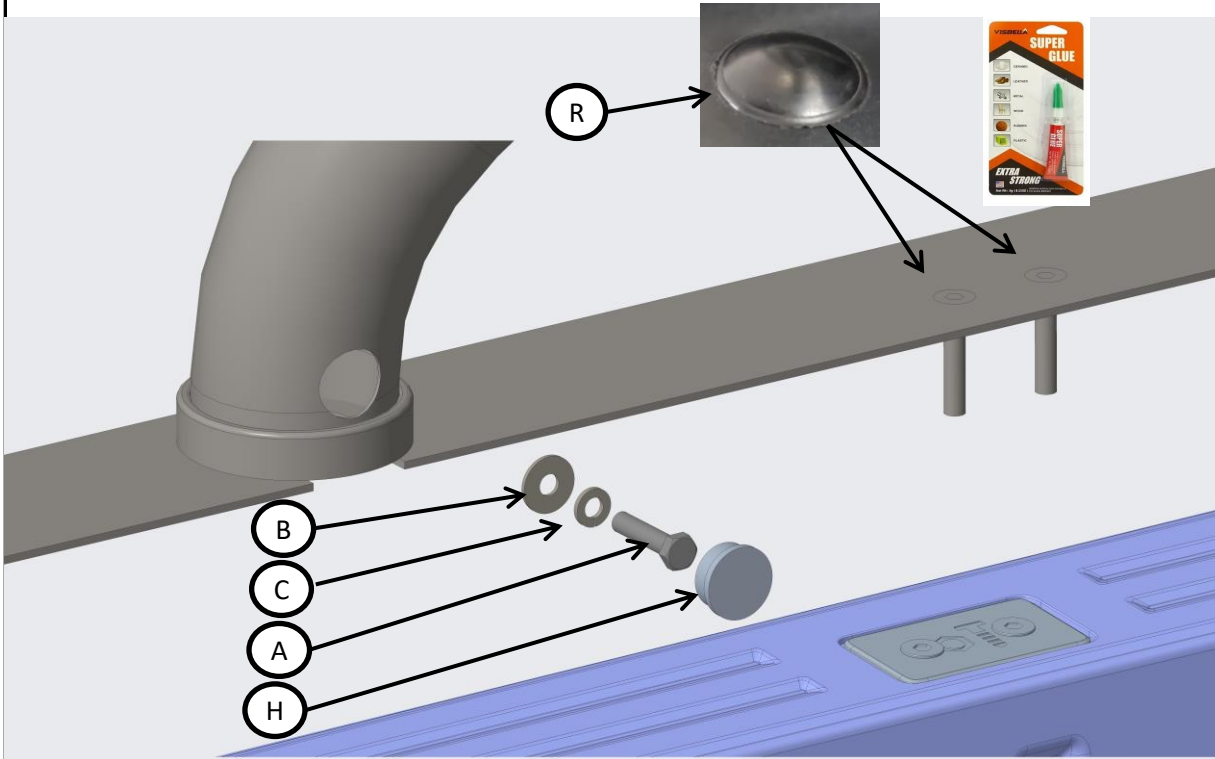

Step #

Description/Method

4

Once the base plate has been loosely mounted, place the assembled bar onto the base and using the fasteners below, loosely mount the entire bar to the base plates. The grommet(H) and the CSK cap(R) will only be required at the end of the fitment, after you have the bar secured.

NB - Use the super glue provided to secure the CSK cap. 1 drop per cap is sufficient. Apply it to the inside on the bolt head.
DO NOT SPILL ON BASE PLATE!

Fitment Instruction:
Ranger Sports Bar

Visual / Graphic Illustration

Step #

Description/Method

5

Once the bar is placed correctly, you can begin to tighten the side plates, then the base plate next and finally you can tighten the bar onto the base plate.

6

Do not forget to fit the grommets(H) into the bar.



Final step

Page 9 of 9

Make sure bar is centralised and tighten all fasteners to specified torque. M8= 22Nm , M10= 42Nm , M6= 9Nm.

