

ACCESSORY FITMENT

Product

Foton Tunland G7 Double cab side steps

Product no.

13502-DFS



60
Minutes

Models : Double Cab

Page 1 of 5

Date : 25-July-2024

DIAGRAM



Kit content:

	Qty	Description		Qty	Description
A	10	M8x25 Sets	H	2	Oval side step
B	12	M8x22x2 Flat washers	I	2	PS and DS front brackets
C	12	M8 Spring washers	J	2	PS and DS middle brackets
D	2	M8 hex nuts	K	2	PS and DS rear brackets
E	12	M8x25 Sets (Black)			
F	12	M8x20x1.6 Flat washers (Black)			
G	12	M8 Spring washers (Black)			

Additional equipment/Material needed for fitment :

Qty		Description	Qty	
1		Ratchet set		
1		Spanner Set		
1		Torque wrench		

Precautions during fitment:

Ensure you have an adequate working space. Ensure that the correct tools and appropriate clothing are used with installation.

Directions for use:

Please follow the steps below, numbered 1 to #.

Fitment Instruction:
Toyota Hilux Double cab side steps

Visual / Graphic Illustration

FIG 1.1



Step #

Description/Method

Step 1.1

Remove running boards. Keep note of where the brackets are being removed as the new brackets will use the same positions.

Fitment Instruction: Toyota Hilux Double cab side steps

Visual / Graphic Illustration

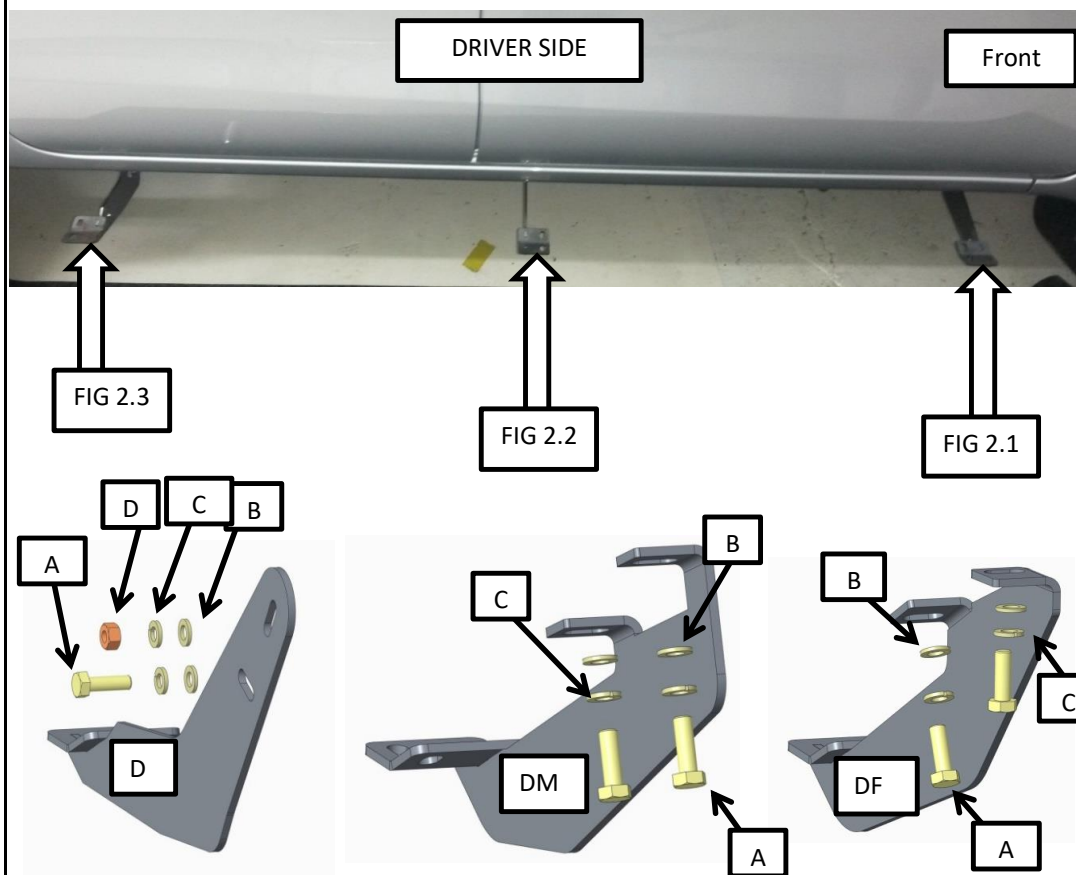

Step #

Description/Method

Step 2.1

Mount the bracket labelled DF to the front drivers side of the vehicle using the kit shown in FIG 2.1

Step 2.2

Mount the bracket labelled DM to the front drivers side of the vehicle using the kit shown in FIG 2.2

Step 2.3

Mount the bracket labelled DB to the back drivers side of the vehicle using the kit shown in FIG 2.3

Do not fully tighten and do the same to both side of the vehicle.

Fitment Instruction: Toyota Hilux Double cab side steps

Visual / Graphic Illustration

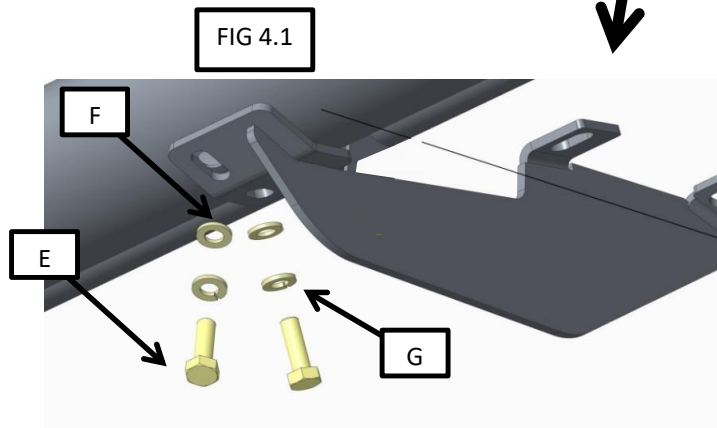

Step #

Description/Method

Step 4.1

Place the side step on to the protruding brackets and using the kit shown in fig 4.1 tighten.

Step 4.2

Now that the side step is tightened to the mounting brackets, you can now fully tighten the brackets to the vehicle. There is adjustment located on the front and middle brackets for sideways adjustment. Make sure brackets and side steps are straight. Tighten using the torque wrench. M8= 22Nm.

COMPLETE

Final step

Page 5 of 5

Make sure bar is centralised and tighten all fasteners to specified torque. M8= 22Nm.

