

# ACCESSORY FITMENT

**Product**

Foton Truckmate Bumper protector

**Part no.**

BS-135012



60  
Minutes

Models : All

Page 1 of 7

Date : 07-08-2025

DIAGRAM



Kit content:

	Qty	Description		Qty	Description
A	1	Bumper Protector	K	6	M10 x 30 sets
B	2	Clamp plate	L	6	M8 x 25 x 2 Flat washers
C	2	Weld Nut Plate	M	2	M8 x 20 x 2 Flat washer
D	1	PS Bottom bracket	N	20	M10 x 30 x 2 Flat washer
E	1	DS Bottom bracket	O	4	M10 x 130 Bolts
F	1	PS top bracket	P	4	M10 Spring Washer
G	1	DS top bracket	Q		M10 Hex Nuts
H	4	M8 x 160mm long bolts	R		M10 Nut caps
I	4	M8 Hex Nuts			
J	4	M8 Spring Washers			

Additional equipment/Material needed for fitment :

Qty		Qty	
	Fitters tool box		

Precautions during fitment:

Directions for use:

Read carefully

## Fitment Instruction: Foton Truckmate Bumper protector

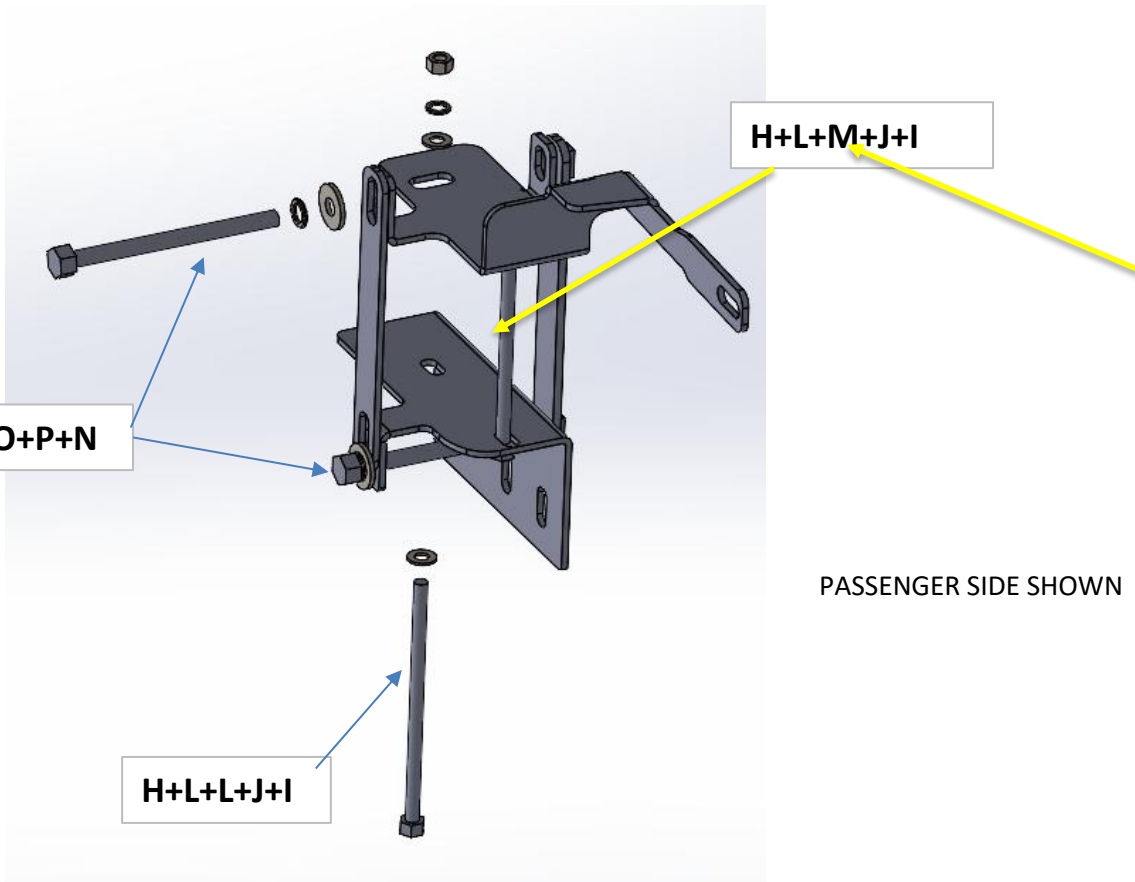
Visual / Graphic Illustration	Step #	Description/Method
 <p style="text-align: right;">PASSENGER SIDE SHOWN</p>	1	Pay close attention to the bracket assembly shown on the left.
	NB	Ensure that the correct washer is used for the bolt.

## Fitment Instruction: Foton Truckmate Bumper protector

Visual / Graphic Illustration



Step #

Description/Method

2

Remove the bumper

3

Fit brackets onto the chassis as shown in the image on the left. Refer to Page 2 for bracket assembly.

**Fitment Instruction:**  
Foton Truckmate Bumper protector

Visual / Graphic Illustration	Step #	Description/Method
	4	Trim the bumper grill as shown in the images on the left.

**Fitment Instruction:**  
**Foton Truckmate Bumper protector**

Visual / Graphic Illustration	Step #	Description/Method
	5	Fit the bumper back on.

**Fitment Instruction:**  
Foton Truckmate Bumper protector

Visual / Graphic Illustration



Step #

Description/Method

6

Mount the bar using the M10 x sets and their rest of the M10 fastners.

Make sure bar is centralised and tighten all fasteners to specified torque. M8= 22Nm , M10= 42Nm , M6= 9Nm.

